

**DESIGN AND IMPLEMENTATION OF POTT PROTECTION
SCHEME USING IEC-61850**

A Thesis Presented for the Master of Science Degree
The University of Tennessee at Chattanooga

Kirpal Singh Doad

July 2010

ACKNOWLEDGEMENTS

I would like to express my sincere gratitude to my family S. Amrik Singh Doad, Smt. Daljit Kaur, Gurbir Doad, Gurpreet Doad, for supporting my efforts all the time. Then, I would like to express my sincere appreciation to my thesis advisor, Dr. Ahmed Eltom, for his guidance and support. Without his help, this thesis would not have been possible.

I would like to thank Dr. Stephen Craven, Mr. Gary Kobet, Mr. Russell Patterson for their invaluable suggestions and guidance. This gave me the great opportunity to learn about relays, which I have never known before. I would also like to thank Mr. Terrence Smith for his assistance. Special thanks are extended to all my teachers and friends who always encouraged me to obtain my master's degree.

Finally, I would like to express my appreciation to the Graduate School office and the engineering faculty of The University of Tennessee at Chattanooga for giving me an opportunity to continue my study in the master's degree of electrical engineering.

ABSTRACT

This study is an attempt to implement the International Electrotechnical Commission (IEC) - 61850 to protect a transmission line using Generic Object Oriented Substation Events (GOOSE) messaging. IEC 61850 describe rules for integration of protection, control, measurement and monitoring functions within a power system network at the process and station control levels. Earlier envisioned for substation automation, IEC 61850 has shown its potential in eliminating substation wiring, enhanced interoperability between vendors and systems. Thus efforts are now being made to expand it to cover substation to control center and substation to substation automation.

In this paper, GE D90 Plus Line Distance Protection relays were used to protect an assumed transmission line scheme through Permissive Overreach Transfer Trip (POTT) communication scheme. Different types of faults were calculated for different locations and tested. GOOSE messages carrying trip signals were transmitted by the relays. The relays operated in the expected tripping zone and picking up right elements thus validating the results. The time delay between tripping the relays at each end of transmission line was found to be ranging between 3 microsecond to 2.9 millisecond.

TABLE OF CONTENTS

CHAPTER	PAGE
1. INTRODUCTION	1
Power System In The Past and Present	1
Power System In The Future	3
2. International Electrotechnical Commission (IEC) 61850	5
IEC 61850 Communication Methods	6
Object Models	7
Substation Configuration Language	8
IEC 61850 GOOSE Message	9
3. POWER SYSTEM SIMULATION	11
Simulated System	11
Sequence Networks	12
Fault Analysis At The Point Of Fault	15
Three-Phase Faults	15
Single-Phase-to-Ground Faults	16
Line-to-Line Faults	17
Double-Phase-to-Ground Faults	18
Fault Calculations at Relay Terminals	19
4. OMICRON CMC 256-3 AND RUGGED COM SWITCH SET UP FOR TESTING THE RELAY	26
Omicron Setup	26
Communication Switch	30
5. INSTALLATION SETTINGS	31
AC Input Modules	31
Power System Frequency	32
Signal Source Settings	32
Grouped Protection Elements	33
Control	39
Digital Fault Recorder	44
6. RESULTS	46
7. CONCLUSIONS	60
REFERENCES	61
APPENDICES	64
APPENDIX 1: RELAY SETTINGS FILE	65

APPENDIX 2	
FAULT CALCULATION USING MATLAB	
CODE FOR RELAY 1 AT STATION G.....	87
APPENDIX 3	
FAULT CALCULATION USING MATLAB	
CODE FOR RELAY 2 AT STATION H.....	90

LIST OF FIGURES

FIGURE	PAGE
2.1 Anatomy of IEC Object name	8
2.2 Example of Time change between GOOSE message publications.....	9
3.1 The simulated system used in distance protection.....	11
3.2 Positive Sequence Network for Fault at 10% of line from Bus G.....	12
3.3 Negative Sequence Network for Fault at 10% of line from Bus G.....	13
3.4 Zero Sequence Network for Fault at 10% of line from Bus G.....	14
3.5 Sequence Network Connection for Three Phase Fault at 10% of line from Bus G.....	15
3.6 Sequence Interconnection for Single-Phase-to-Ground Fault at 10% of line from Bus G.....	16
3.7 Sequence Interconnection for Line-to-Line Fault at 10% of line from Bus G.....	17
3.8 Sequence Interconnection for Double-Phase-to-Ground Fault at 10% of line from Bus G.....	19
4.1 Connection Diagram for OMICRON Test Set.....	26
4.2 The OMICRON Test Universe Home page.....	27
4.3 State Sequence Window	27
4.4 Detail View Window.....	28
4.5 Four states selected for testing the line.....	28
4.6 Hardware configuration selection.....	29
4.7 Settings Binary Inputs.....	29
4.8 Setting Binary Outputs.....	29
4.9 Backpanel view of Rugged Com Switch.....	30

5.1 Phase distance Zone 1 operation logic.....	35
5.2 Phase distance Zone 2 operation logic.....	35
5.3 Phase distance element scheme logic.....	36
5.4 Ground distance zone 1 operation logic.....	37
5.5 Ground distance zone 2 operation logic.....	37
5.6 Ground distance zone 1 scheme logic.....	38
5.7 Phase instantaneous overcurrent scheme logic.....	39
5.8 Permissive Overreach Transfer Trip Scheme Logic.....	41
5.9 Trip output scheme logic sheet1.....	42
5.10 Trip output scheme logic sheet 2.....	43
6.1 Relay 1 oscillography for single line to ground fault.....	46
6.2 Relay 2 oscillography for single line to ground fault.....	48
6.3 Relay 1 oscillography for three phase fault.....	49
6.4 Relay 2 oscillography for three phase fault.....	50
6.5 Relay 1 oscillography for line to line fault.....	51
6.6 Relay 2 oscillography for line to line fault.....	52
6.7 Relay 1 oscillography for double line to ground fault.....	53
6.8 Relay 2 oscillography for double line to ground fault.....	55
6.9 Relay 1 GOOSE message and tripping time (10% fault from station G).....	56
6.10 Relay 2 GOOSE message and tripping time (90% fault from station G).....	57
6.11 Relay 1 GOOSE message and tripping time (50% fault from station G).....	58
6.12 Relay 2 GOOSE message and tripping time (50% fault from station G).....	59

CHAPTER 1

INTRODUCTION

POWER SYSTEM IN THE PAST AND PRESENT

The deregulation of electricity has brought new suppliers into the electricity market which has increased the competition. This resulted in the operation of power system close to its peak limits. It requires the integration of equipment and systems to be efficient at peak loads. To achieve this goal the equipment and systems have to be interoperable and interfaces, protocols and data models must be compatible [1].

The microprocessor relays not only provide subcycle tripping during the fault conditions but also have communication interfaces to provide AC voltage and current metering, power system and relay status reporting and event records and oscillography. Since proprietary Intelligent Electronic Device (IED) manufacturers follow their own way, an IED may or may not be able to communicate with more than one IED. If it did communicate with more than one IED, the sequence and structure of message was unique [1] and the user can not interconnect different brands of IEDs. To overcome this problem, the system integrators use gateway or translator devices to bring all data into a common format [1]. Thus, the user has to spend a lot of time, money and efforts on learning the operating mannerism and software packages of each vendor [1] which is not very much efficient. International Electrotechnical Commission (IEC) 61850 specifies how the data should be organized [4], thus making it easier to share data between multivendors.

From the above discussion, it can be concluded that two important issues for the proper operation of power system are – how fast the data is communicated and the way data is communicated. In the 1980's, the high speed communication data paths operating

at 64,000 bits per second were available. Utility Communication Architecture (UCA) in 1988 took its full benefit. The concepts and fundamental work done in UCA laid the foundation for International Electrotechnical Commission (IEC) - 61850 [4]. IEC 61850 standardizes the different communication protocols used by the protective relay vendors so that different relays could exchange data with each other without any difficulty and without special need of converters [5]. In 1990's Ethernet providing a speed of 10-100 megabits per second was available and IEC 61850 took its advantage for high speed peer-to-peer and client server purposes. As Ethernet helped in digitizing the messages and each message can carry the sender and receiver address, it helped in removing lots of wiring from the substation. Other requirements observed which led to the development of IEC 61850 standard were high speed IED-to-IED communication, high availability, networkable, reduced cost, reduced construction and commissioning time, support for voltage and current samples data, support for file transfer and security [14, 15].

The IEC 61850 delivers a number of benefits over its predecessors due to its object modeling approach, use of Ethernet priority tagging and through the availability of virtual connections. Some of the benefits are discussed below [4, 15]:

- 1) Eliminate procurement ambiguity: User can define exactly and unambiguously what is expected to be provided in each device that is not subject to misinterpretations by suppliers.
- 2) Lower installation cost: By programming the sender and receiver in the IEDs, the GOOSE messages can be sent through Ethernet without any delay and without any fear of broken wire, since the connections can be monitored through the GOOSE

messages. This reduces a wiring and construction cost. GOOSE is a digital message which carries information from one point to another.

- 3) Lower transducer cost: Earlier each IED which needed to communicate, required a separate transducer. But, in IEC 61850 standard, single merging unit supporting Sampled Measured Values (SMV) can deliver these signals to many devices while using just one transducer, thus reducing transducer, wiring, calibration and maintenance costs.
- 4) Lower commissioning cost: Client applications can retrieve the point list directly from the device or import it via the Substation Configuration Language (SCL) file thus eliminating the need to configure each point.
- 5) Lower integration cost: The cost to integrate substation data into the enterprise is substantially reduced by using the same networking technology that is widely used across utility enterprise. IEC 61850 are capable of delivering data without any extra communication front-ends and reconfiguring devices.

POWER SYSTEM IN THE FUTURE

The IEC 61850 has emerged as a powerful protocol which can accommodate future changes in the communication sector since the more expensive application layer is independent of the communication layer. Earlier IEC 61850 was developed for the automation within the substation. Realizing its benefits, its scope has been extended and work is in progress to define the rules for substation to substation and substation to control center automation [4, 15]. Line protection was not in the scope of IEC 61850

earlier, but the standard had all the logical nodes and services to model line distance protection and line differential protection [18].

This study is an attempt to use the IEC 61850 GOOSE technology for the line protection. A protection line scheme is assumed and fault calculations are done for single line to ground, three phase fault, line to line fault and line to line to ground fault. The GE D90^{Plus} Line distance protections relays were both used and tested. The settings for the line protection and GOOSE messaging were done. The results were verified through the oscillography and an open source network protocol analyzer Wireshark. A similar project in operation [19] used Ethernet cards to transmit GOOSE messages on the wide area network. The flow of the paper is discussed below:

In Chapter 2, background details of IEC-61850 and its features is given.

In Chapter 3, simulated power systems are described. An example for fault calculation is shown.

Chapter 4 describes how to use Communication Switch and OMICRON CMC 256-3 test set and OMICRON Test Universe V2.22 SR 1 software to set and test the relays.

In Chapter 5, both setting and testing GE D90^{Plus} for line protection with Permissive Overreaching Transfer Trip (POTT) communication scheme are described.

In Chapter 6, the overall conclusion of this thesis is summarized, and some ideas for future research are suggested.

CHAPTER 2

INTERNATIONAL ELECTROTECHNICAL COMMISSION (IEC) 61850

A large number of Intelligent Electronic Devices (IEDs) are available in the market. Each manufacturer uses a different protocol for the operation of its IEDs or relays. These protocols work very well when employed alone. But, they pose a very difficult situation when different vendor relays have to exchange data. They need to have very costly converters to communicate between different vendor relays. The working groups of IEC Technical Committee TC57 are extending IEC 61850 for communications between substations and between substation and control center [13].

The documentation of IEC 61850 standard is divided into ten parts which are listed below in Table 1. Parts 1, 2, 3, 4 and 5 give overview and general requirements of

Table 1. Sections of IEC 61850 documentation [15]

Part	Title
1	Introduction and Overview
2	Glossary of Terms
3	General Requirements
4	System and Project Management
5	Communication Requirements for Functions and Device Models
6	Configuration Description Language for Communication in Electrical Substation Related to IEDs
7	Basic Communication Structure for Substation and Feeder Equipment
7.1	Principles and Models
7.2	Abstract Communications Service Interface (ACSI)
7.3	Common Data Classes
7.4	Compatible Logical Node Classes and Data Classes
8	Specific Communication Service Mapping (SCSM)
8.1	Mapping to MMS and to ISO/IEC 8802-3
9	Specific Communication Service Mapping (SCSM)
9.1	Sampled Values over Serial Unidirectional Multidrop Point-to-Point Link
9.2	Sampled Values over ISO/IEC 8802-3
10	Conformance Testing

the communication in a substation [15]. Part 6 states Extensible Markup Language (XML) based language called Substation Configuration Language (SCL) for IED configuration and its relation to other IEDs within a substation. The data items and services are made independent of underlying protocols which is given the term “abstracting” in the standard defined in part 7. Section 8 defines how these abstract services are “mapped” into a presentation layer and Ethernet link layer [3, 15]. Section 9 define mapping of Sample Measured Values onto an Ethernet data frame. Section 10 define the tests required to determine “conformance” with the IEC 61850 standard [15].

IEC-61850 COMMUNICATION METHODS

Earlier technologies EIA-232 point to point and EIA-485 multidrop communications port within the IEDs were slow with a speed of 38.4 kilobits per second [13]. IEC 61850 use the high speed Ethernet technology with a data transfer rate of 100 Megabits per second. Two ways of communication available are the client-server and peer-to-peer communication. IEC 61850 uses two real time peer-to-peer communication methods called Generic Substation Event (GSE) messaging and Sampled Value (SV). GSE messages can be sent either through the Generic Substation State Event (GSSE) or through Generic Object Oriented Substation Event (GOOSE). GOOSE is more flexible because it can send both binary and analog values whereas GSSE can send only binary values [13].

GSE and SV messages are multicast. Multicast means that messages can be sent only in one group in a network. They are not device (IEDs) specific because the messages do not include the device address.

OBJECT MODELS

The intent of the IEC 61850 is to standardize the model i.e. organization of data by set of standard model structures for data and rules defining how to exchange the data [13, 14]. The standard “abstracts” the data models, which means that it keeps the data models independent from the communication systems which helps it to achieve interoperability. Any future advancements in the communication layers does not affect the data model thus making the standard flexible to the future technologies. In this data model, the smallest possible element that exchanges information and refers to these elements is called Logical Node (LN). Examples of Logical Nodes are given below and their names begin with the letters given in the parenthesis: Metering and measurement (M), Generic function (G), Supervisory control (C), Protection (P), Protection related (R), Sensors (S), Instrument transformer (T), Switchgear (X), Power transformer (Y) and Other equipment (Z) eg. XCBBR – circuit breaker logical node, MMXU – metering and measurement logical node.

Each element of data within the logical nodes adapts to the specifications of a Common Data Class (CDC). CDC defines the type and structure of data within a logical node [5, 13]. Examples of CDCs are status information, measured information, controllable status information, status settings and analog settings. The Abstract Communication Service Interface (ACSI) models are abstract definitions that describe communication between clients and remote servers [16]. These abstract models can be mapped to specific protocol stack based on Manufacturing Message Specification (MMS), TCP/IP and Ethernet. While mapping IEC 61850 objects to MMS, the standard specifies a method of transforming the model information into a named MMS variable

object, that results into a unique and unambiguous reference for each element of data in the model [5].

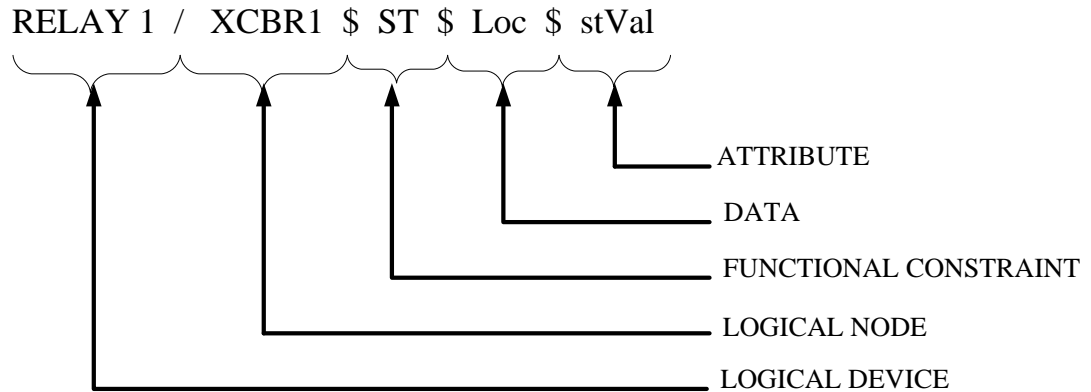

Figure 2.1: Anatomy of IEC-61850 object name.

SUBSTATION CONFIGURATION LANGUAGE (SCL)

SCL is based on Extensible Markup Language (XML) to describe the configuration of IEC 61850 based systems [5, 13]. The various SCL based files are:

- 1) System Specification Description (SSD) file: outlines substation automation project.
- 2) IED Capability Description (ICD) file: describes available functions (LNs) and services available from an IED.
- 3) Substation Configuration Description (SCD) file: describes relationship among IEDs in the substation automation project and their information exchange structure.
- 4) Configured IED description (CID) file: final file to download into the IED to enable its configured functions.

IEC 61850 GOOSE MESSAGE

As discussed earlier in this chapter, IEC 61850 uses two types of multicast messaging techniques GOOSE and GSSE. GSSE is binary only whereas GOOSE can support both binary and analog values. In order to multicast the GOOSE messages, the addressing layer is removed. This reason is why GOOSE messages are not routable and cannot be send through a Wide Area Network (WAN). It can be routed inside a Local Area Network (LAN) because the network address is a group address and not a specific device address [13].

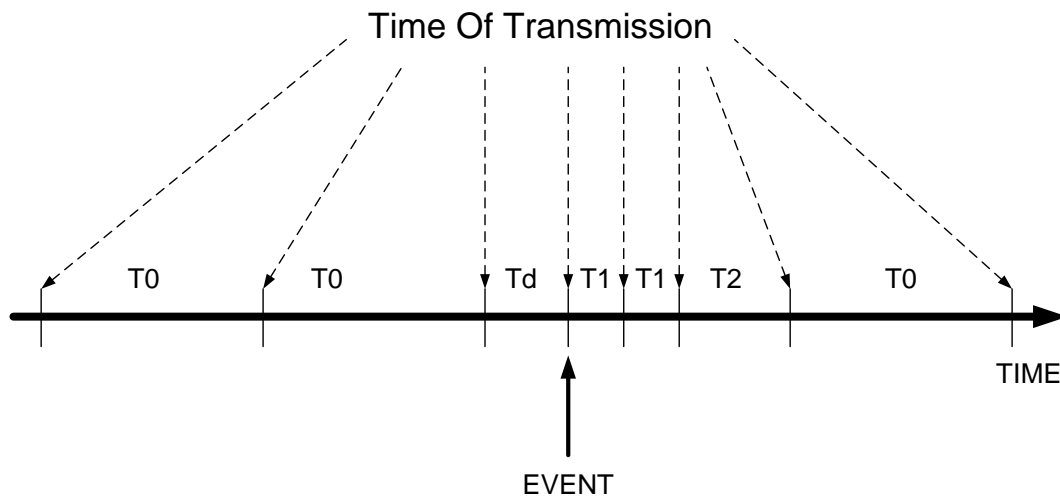

Figure 2.2 : Example of Time change between GOOSE message publications

The Figure 2.2 shows GOOSE message is given a parameter max time (mt) to wait between message publications. In present case $mt = T0$. As soon as there is a change in data set, the messages are published very frequently and the time of transmission (tot) is 4 milliseconds [13]. The messages are sent very frequently to increase the probability that all subscribers receive them. After the initial rapid publications, the tot increases till it reaches the normal publication time of mt .

Publisher calculates time to live (*ttl*) for every message, based on the next *tot*. *ttl* is $2(tot)$ when *tot* is equal to T_0 and *ttl* is $3(tot)$ when *tot* is other than T_0 . Subscribers constantly calculate time to wait (*ttw*) based on *ttl*. Subscribers declare the data “stale” if the *ttw* expires and they did not receive new message from the publisher. It then assumes that communication is lost and modifies its relay logic accordingly [13].

To reduce the burden on the LAN because of the constantly multicast of GOOSE messages two techniques are used. First is the Virtual LAN (VLAN) and the other is Priority Tagging. VLAN isolates network traffic from different departments inside one enterprise whereas GOOSE messages can be tagged from 0 to 7 according to the priority requirement. The default GOOSE message is given a priority level of 4. Trip messages are set at high priority.

CHAPTER 3
POWER SYSTEM SIMULATION

SIMULATED SYSTEM

To test IEC-61850 GOOSE messaging, a transmission line shown in Figure 3.1 was assumed and simulated. A 100MVA, 161kV, 26 mile transmission line was selected whose positive and negative sequence impedance is $(0.259+ j0.7788)$ ohms per mile and zero sequence impedance is three times the positive sequence impedance. The sources have impedance of $(j10)$ ohms, where Source 1 is working at a voltage level of 1 per unit at angle zero and Source 2 is working at a voltage level of 1 per unit at an angle of 5 degrees.

The power system shown in Figure 3.1 is used to demonstrate the use of digital relay and GOOSE messages for POTT communication scheme. Faults were studied at different locations on the transmission line. MATLAB code was written for the calculation of the fault currents and voltages which is attached in the appendix.

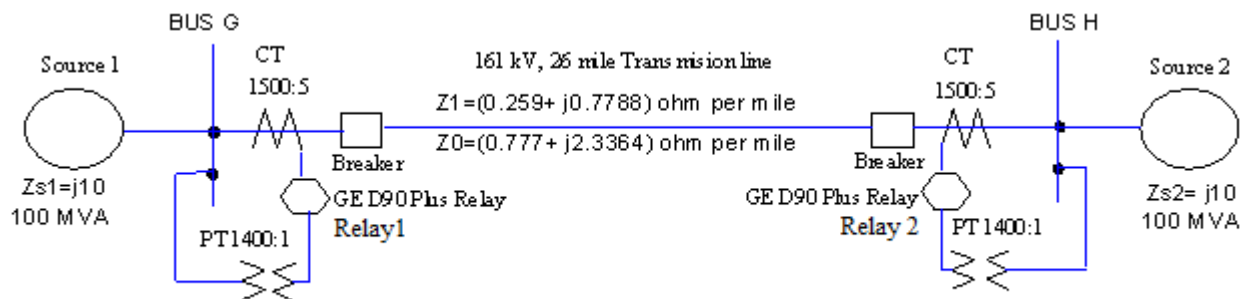

Figure 3.1 The simulated system used in distance protection.

SEQUENCE NETWORKS

Per unit impedances for the power system shown in Figure 3.1 are calculated using 100 MVA base and 161kV base on the transmission line. Assuming a fault occurring at bus G, the positive, negative and zero sequence networks are presented below:

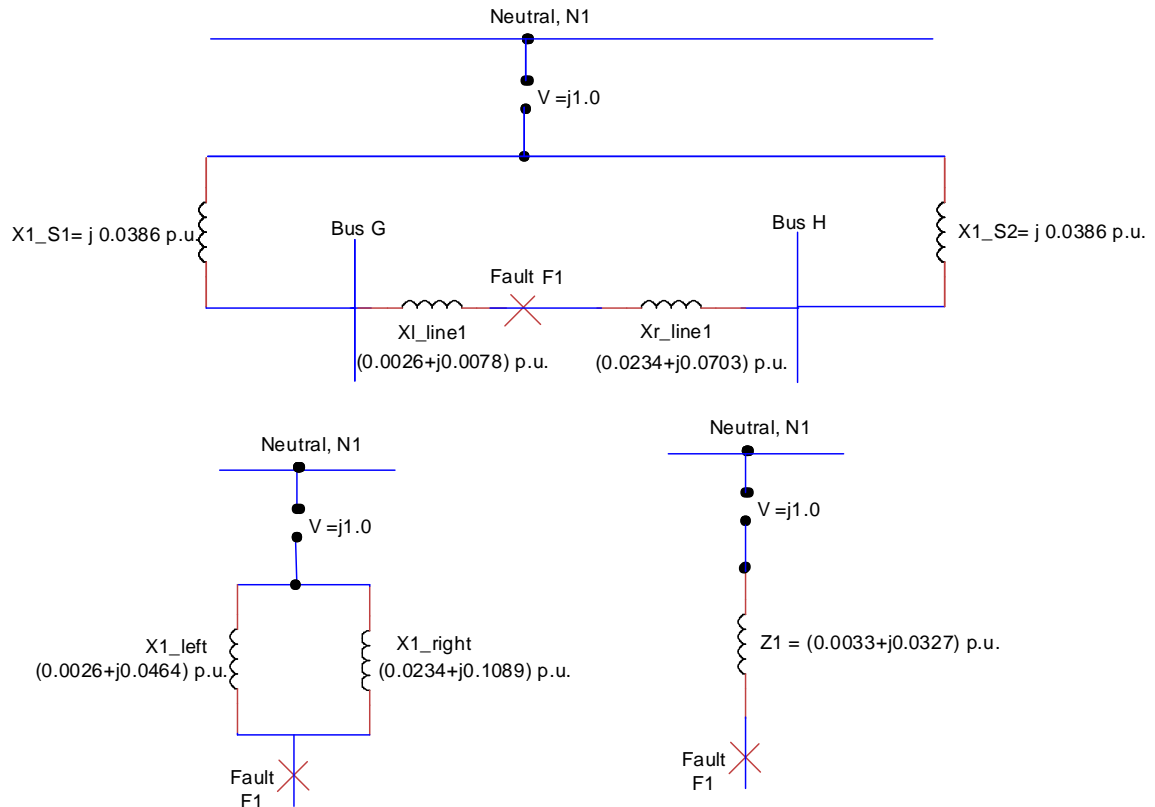

Figure 3.2 Positive Sequence Network for Fault at 10% of line from Bus G.

$$\begin{aligned}
 Z_{base} &= \text{kV}_{base}^2 / \text{MVA}_{base} \\
 &= 161 \cdot 161 / 100 \text{ ohms} \\
 &= 259.21 \text{ ohms}
 \end{aligned}$$

$$X1_S1 = (j10) / 259.21 = j 0.0386 \text{ p.u.}$$

$$X1_S2 = (j10) / 259.21 = j 0.0386 \text{ p.u.}$$

$$\begin{aligned}
X_{l_line1} &= 10\% \text{ of line impedance} \\
&= 10\% \text{ of } (26 \cdot (0.259 + j 0.7788)) / 259.21 \text{ p.u.} \\
&= (0.0026 + j 0.0078) \text{ p.u.} \\
X_{r_line1} &= 90\% \text{ of line impedance} \\
&= 90\% \text{ of } (26 \cdot (0.259 + j 0.7788)) / 259.21 \text{ p.u.} \\
&= (0.0234 + j 0.0703) \text{ p.u.}
\end{aligned}$$

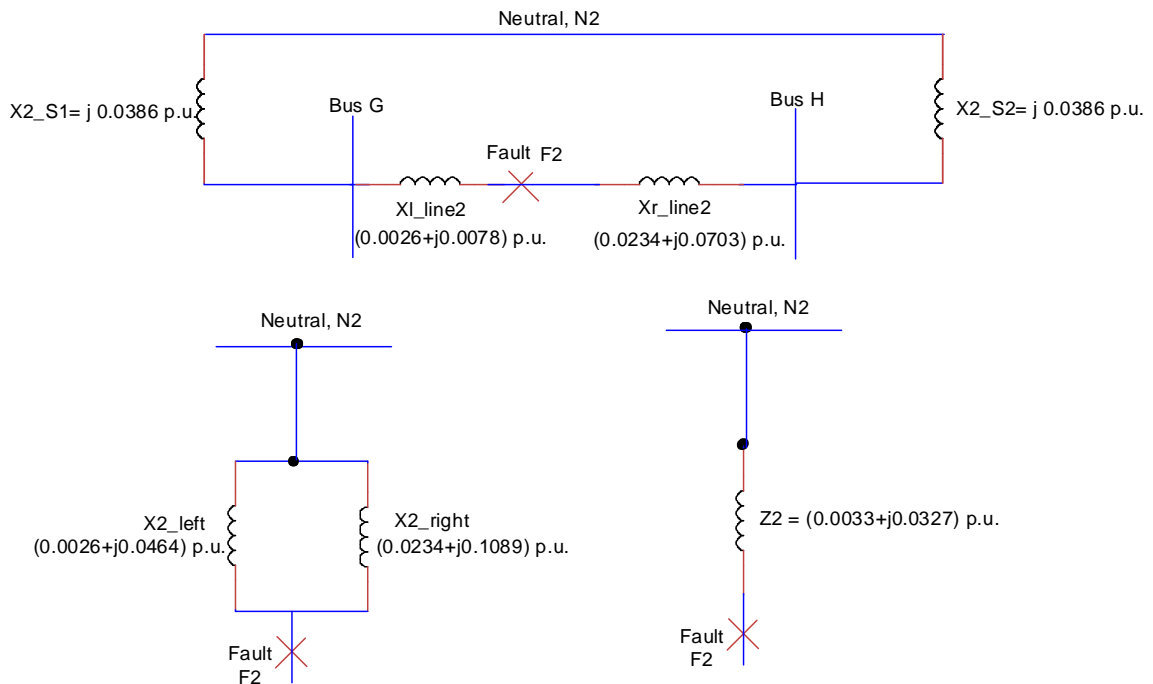

Figure 3.3 Negative Sequence Network for Fault at 10% of line from Bus G.

$$\begin{aligned}
X_{2_S1} &= (j10) / 259.21 = j 0.0386 \text{ p.u.} \\
X_{2_S2} &= (j10) / 259.21 = j 0.0386 \text{ p.u.} \\
X_{l_line2} &= 10\% \text{ of line impedance} \\
&= 10\% \text{ of } (26 \cdot (0.259 + j 0.7788)) / 259.21 \text{ p.u.} \\
&= (0.0026 + j 0.0078) \text{ p.u.} \\
X_{r_line2} &= 90\% \text{ of line impedance}
\end{aligned}$$

$$= 90\% \text{ of } (26 * (0.259 + j 0.7788)) / 259.21 \text{ p.u.}$$

$$= (0.0234 + j 0.0703) \text{ p.u.}$$

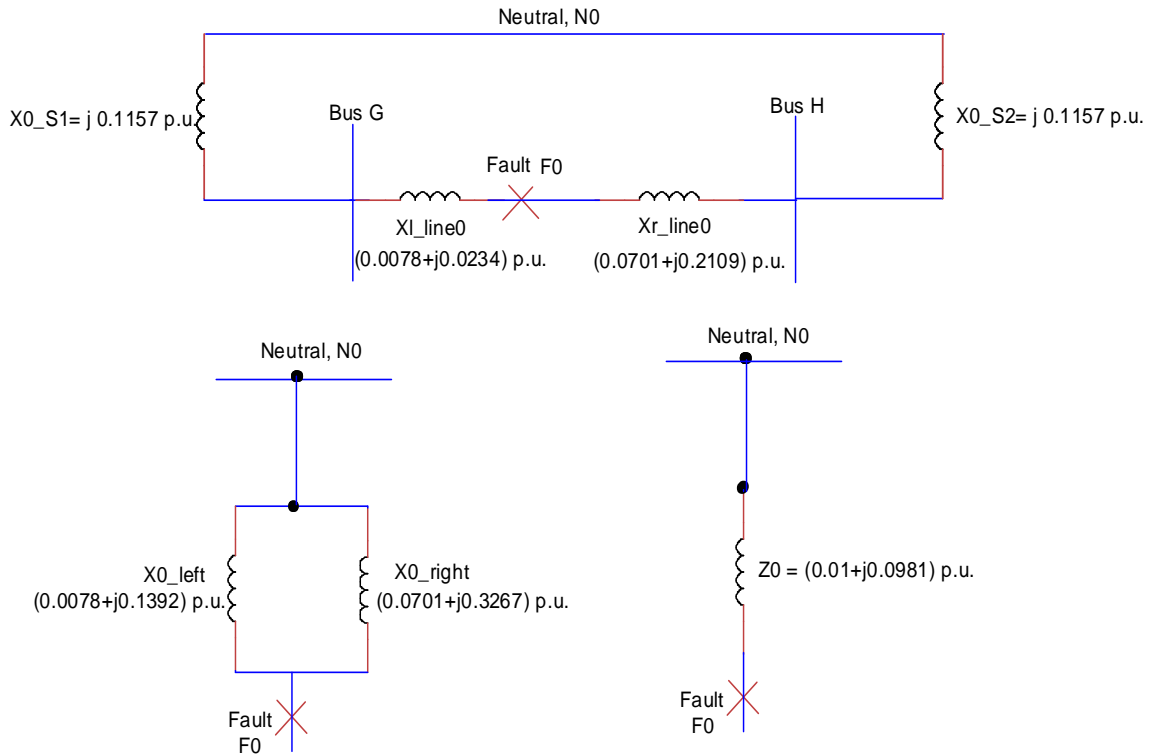

Figure 3.4 Zero Sequence Network for Fault at 10% of line from Bus G.

$$X0_S1 = (j30) / 259.21 = j 0.1158 \text{ p.u.}$$

$$X0_S2 = (j30) / 259.21 = j 0.1158 \text{ p.u.}$$

$$Xl_line0 = 10\% \text{ of line impedance}$$

$$= 10\% \text{ of } (26 * (0.777 + j 2.2364)) / 259.21 \text{ p.u.}$$

$$= (0.0078 + j 0.0234) \text{ p.u.}$$

$$Xr_line0 = 90\% \text{ of line impedance}$$

$$= 90\% \text{ of } (26 * (0.777 + j 2.2364)) / 259.21 \text{ p.u.}$$

$$= (0.0701 + j 0.2109) \text{ p.u.}$$

FAULT ANALYSIS AT THE POINT OF FAULT

Three Phase Fault:

For a three phase fault only the positive sequence network is used for fault [6].

Three phase fault is a symmetrical fault and is shown in Figure 3.5.

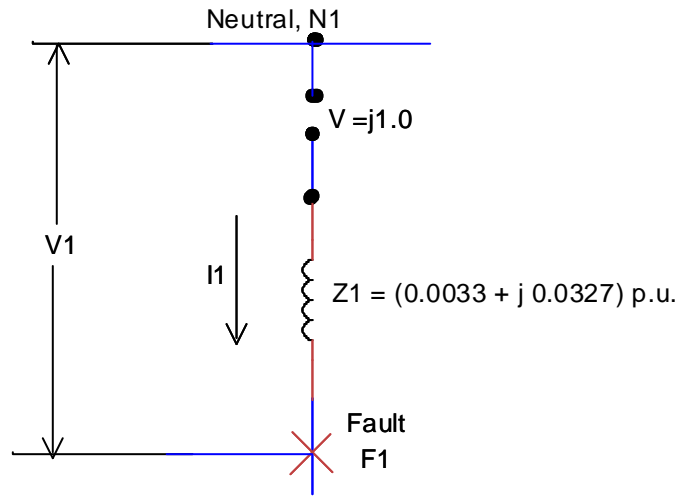

Figure 3.5 Sequence Network Connection for Three Phase Fault at 10% of line from Bus G.

$$\begin{aligned}
 I_1 &= V / Z_1 \\
 &= 1 / (0.0033 + j 0.0327) \\
 &= (3.0885 - j30.2679) \text{ p.u.} \\
 &= 30.4251 \text{ p.u. at an angle of } -84.17^\circ \\
 &= (30.4251 \times 100 \text{ MVA}) / (1.732 \times 161 \text{ kV}) \text{ A} \\
 &= 10910.8 \text{ A at } 161 \text{ kV}
 \end{aligned}$$

The fault currents for a three-phase fault at bus G would be as follows:

$$\begin{aligned}
 I_{aF} &= I_1 = 10910.8 \angle -84.17^\circ \text{ A} \\
 I_{bF} &= a^2 \times I_1 = 10910.8 \angle 155.82^\circ \text{ A} \\
 I_{cF} &= a \times I_1 = 10910.8 \angle 35.82^\circ \text{ A}
 \end{aligned}$$

The voltages for a three-phase fault would be zero at the fault point i.e. bus G.

Single-Phase-to-Ground Faults:

For a single-phase-to-ground fault (phase-a-to-ground) at bus G, the sequence interconnection is shown in Figure 3.6.

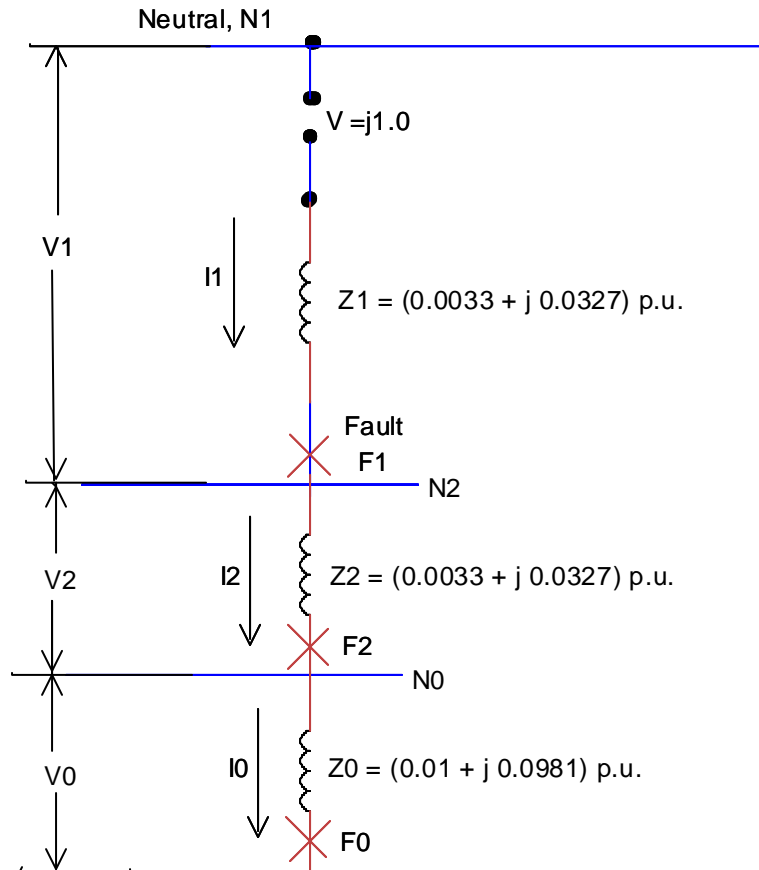

Figure 3.6 Sequence Interconnection for Single-Phase-to-Ground Fault at 10% of line from Bus G.

$$\begin{aligned}
 I_1 = I_2 = I_0 &= V / (Z_1 + Z_2 + Z_0) \\
 &= (0.6177 + j 6.0536) \text{ p.u.} \\
 &= 6.085 \text{ p.u. at an angle of } -84.17 \text{ degrees} \\
 &= (6.085 \times 100 \text{ MVA}) / (1.732 \times 161) \text{ A} \\
 &= 2182.2 \text{ A at } 161 \text{ kV}
 \end{aligned}$$

The fault currents for a single-phase-to-ground fault at bus G would be as follows:

$$\begin{aligned}
 I_{aF} &= I_0 + I_1 + I_2 &= 6546.5 \angle -84.17^\circ \text{ A} \\
 I_{bF} &= I_0 + a^2 I_1 + a I_2 &= 0 \text{ A} \\
 I_{cF} &= I_0 + a I_1 + a^2 I_2 &= 0 \text{ A}
 \end{aligned}$$

The fault voltages for a single-phase-to-ground fault at bus G would be as follows:

$$\begin{aligned}
 V_{aF} &= V_0 + V_1 + V_2 &= 0 \text{ V} \\
 V_{bF} &= V_0 + a^2 V_1 + a V_2 &= 116,100 \angle -136.10^\circ \text{ V} \\
 V_{cF} &= V_0 + a V_1 + a^2 V_2 &= 116,100 \angle 136.10^\circ \text{ V}
 \end{aligned}$$

Line-to-Line Faults:

For a line-to-line fault (a fault between phase-b and phase-c) at bus G, the sequence interconnection is shown in Figure 3.8.

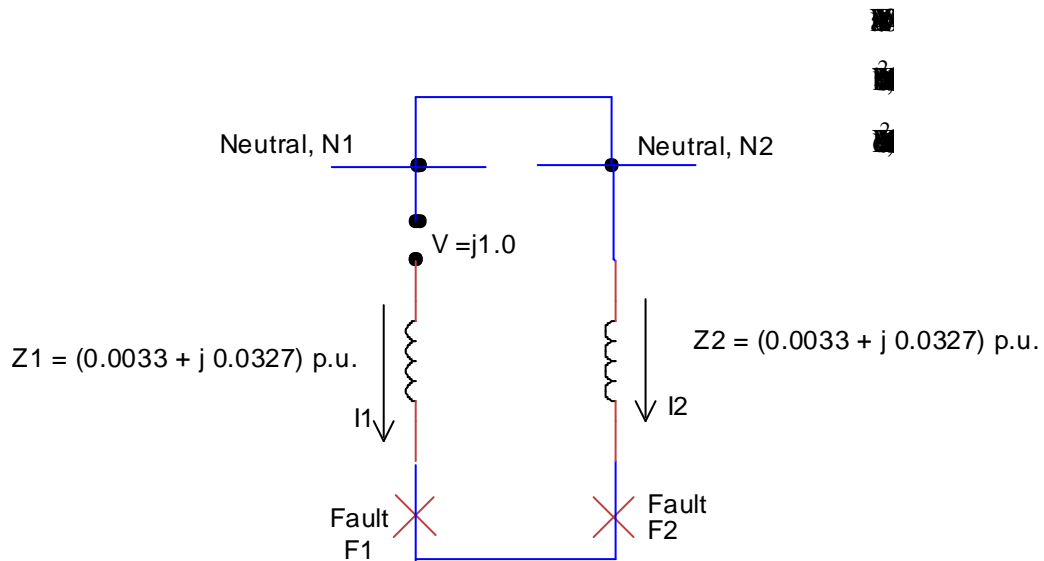

Figure 3.7 Sequence Interconnection for Line-to-Line Fault at 10% of line from Bus G.

$$\begin{aligned}
 I_1 &= V / (X_1 + X_2) \\
 &= 15.21 \text{ p.u.}
 \end{aligned}$$

$$\begin{aligned}
&= (15.21 \times 100\text{MVA}) / (1.732 \times 161) \\
&= 5455.4 \text{ A at } 161 \text{ kV} \\
I_2 &= 5455.4 \text{ A at } 161 \text{ kV at an angle of } 180 \text{ degrees}
\end{aligned}$$

The currents for a double-phase fault at bus G would be as follows:

$$\begin{aligned}
I_{aF} &= I_0 + I_1 + I_2 &= 0 \text{ A} \\
I_{bF} &= I_0 + a^2 I_1 + a I_2 &= 9448.8 \angle -174.17^\circ \text{ A} \\
I_{cF} &= I_0 + a I_1 + a^2 I_2 &= 9448.8 \angle 5.82^\circ \text{ A}
\end{aligned}$$

The fault voltages for a double-phase fault at bus G would be as follows:

$$\begin{aligned}
V_{aF} &= V_0 + V_1 + V_2 &= 92956 \angle 0^\circ \text{ V} \\
V_{bF} &= V_0 + a^2 V_1 + a V_2 &= 46478 \angle 180^\circ \text{ V} \\
V_{cF} &= V_0 + a V_1 + a^2 V_2 &= 46478 \angle 180^\circ \text{ V}
\end{aligned}$$

Double-Phase-to-Ground Faults:

A double-phase-to-ground fault (a fault between phase-b and phase-c to ground) at bus G is similar to the double-phase fault, except for the additional zero sequence network that is connected parallel to it. The sequence interconnections are shown in Figure 3.8.

$$\begin{aligned}
I_1 &= V / [Z_1 + ((Z_0 \times Z_2) / (Z_0 + Z_2))] \\
&= 17.38 \text{ p.u.} \\
&= (17.38 \times 100\text{MVA}) / (1.732 \times 161\text{kV}) \\
&= 6234.8 \text{ A at } 161 \text{ kV} \\
I_2 &= -I_1 \times [(Z_0) / (Z_0 + Z_2)] \\
&= -13.03 \text{ p.u.} \\
&= (-13.03 \times 100\text{MVA}) / (1.732 \times 161) \\
&= 4676.1 \text{ A at } 161 \text{ kV at an angle of } 180 \text{ degrees} \\
I_0 &= -I_1 \times [(Z_2) / (Z_0 + Z_2)]
\end{aligned}$$

$$\begin{aligned}
&= -4.34 \text{ p.u.} \\
&= (-4.34 \times 100\text{MVA}) / (1.732 \times 161) \\
&= 1558.7 \text{ A at 161 kV at an angle of 180 degrees}
\end{aligned}$$

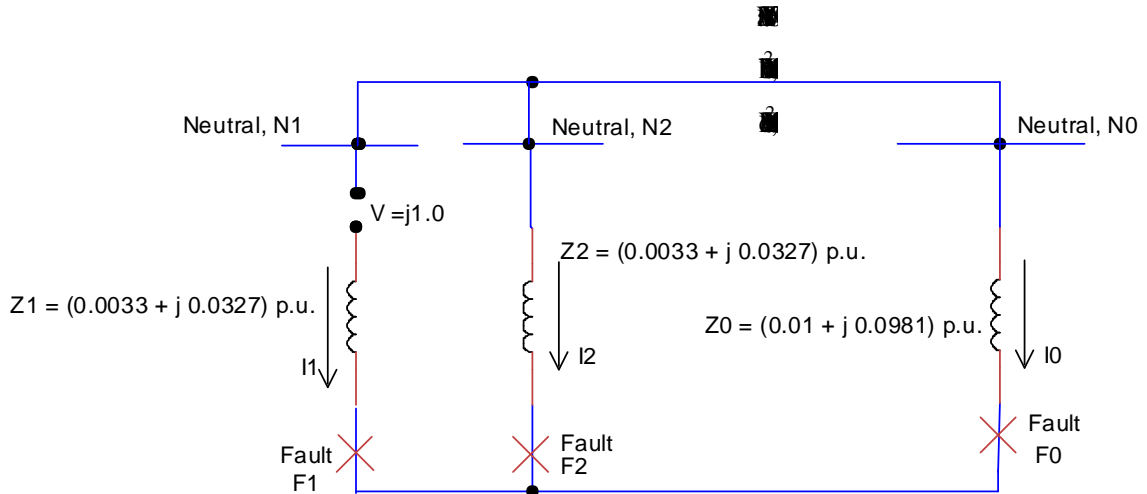

Figure 3.8 Sequence Interconnection for Double-Phase-to-Ground Fault at 10% of line from Bus G.

The currents for a double-phase-to-ground fault at bus G would be as follows:

$$\begin{aligned}
I_{aF} &= I_0 + I_1 + I_2 = 0 \text{ A} \\
I_{bF} &= I_0 + a^2 I_1 + a I_2 = 9733.7 \angle -171.92^\circ \text{ A} \\
I_{cF} &= I_0 + a I_1 + a^2 I_2 = 9733.7 \angle 19.72^\circ \text{ A}
\end{aligned}$$

The fault voltages for a double-phase-to-ground fault at bus G would be as follows:

$$\begin{aligned}
V_{aF} &= V_0 + V_1 + V_2 = 119520 \angle 0^\circ \text{ V} \\
V_{bF} &= V_0 + a^2 V_1 + a V_2 = 0 \text{ V} \\
V_{cF} &= V_0 + a V_1 + a^2 V_2 = 0 \text{ V}
\end{aligned}$$

Fault Calculations at Relay Terminals:

The fault currents and voltages at the terminals of relay are calculated using below given formulas for any kind of fault. Since, the procedure for calculating fault

currents and voltages is the same for all types of faults, calculations are shown only for three phase fault. Other fault values can be calculated using the MATLAB code attached in APPENDIX 1.

Sequence current on the primary of the instrument transformer is:

$$I_0 = \frac{I0 * X0_right}{X0_right + X0_left} \quad 3.1$$

Similarly, Positive sequence current on primary of the instrument transformer is:

$$I_1 = \frac{I1 * X1_right}{X1_right + X1_left} \quad 3.2$$

and, Negative sequence current on primary of the instrument transformer is:

$$I_2 = \frac{I2 * X0_right}{X2_right + X2_left} \quad 3.3$$

The phase currents at the instrument transformer can be calculated using equation 3.1, 3.2 and 3.3.

$$I_A = I_0 + I_1 + I_2 \quad 3.4$$

$$I_B = I_0 + a^2 I_1 + a I_2 \quad 3.5$$

$$I_C = I_0 + a I_1 + a^2 I_2 \quad 3.6$$

$$I_{base_ct} = 1000 * \frac{MVA_{base}}{1.732 * 161 * ctr}$$

Now, phase currents at relay can be found using equation 3.4, 3.5 and 3.6.

$$I_a = I_A * I_{base_ct}$$

$$I_b = I_B * I_{base_ct}$$

$$I_c = I_C * I_{base_ct}$$

Voltages at the primary of the instrument transformer are

$$V_0 = V_0 + (I_0 * X_{l_line0}) \quad 3.7$$

$$V_1 = V_1 + (I_1 * X_{l_line1}) \quad 3.8$$

$$V_2 = V_0 + (I_2 * X_{l_line2}) \quad 3.9$$

Using equations 3.7, 3.8 and 3.9 phase voltages at instrument transformer are found to be:

$$V_A = V_0 + V_1 + V_2 \quad 3.10$$

$$V_B = V_0 + a^2 V_1 + a V_2 \quad 3.11$$

$$V_C = V_0 + a V_1 + a^2 V_2 \quad 3.12$$

$$V_{base_pt} = \frac{1000 * 161}{1.732 * ptr}$$

Using equations 3.10, 3.11 and 3.12, voltages at the relay are calculated as follows:

$$V_a = V_A * V_{base_pt}$$

$$V_b = V_B * V_{base_pt}$$

$$V_c = V_C * V_{base_pt}$$

Following above equations fault currents and voltages for three phase fault at relay 1 are calculated as follows:

Sequence current on the primary of the instrument transformer is:

$$I_0 = 0$$

$$I_1 = (1.2034 - j21.48) * (0.0234 + j0.1089) / ((0.0026 + j0.0464) + (0.0234 + j0.1089)) \\ = (1.2034 - j21.4887) \text{ p.u.}$$

$$I_2 = 0$$

$$I_A = I_0 + I_1 + I_2 = (1.2034 - j21.4887) \text{ p.u.}$$

$$I_B = I_0 + a^2 I_1 + a I_2 = (-19.2109 + j9.7022) \text{ p.u.}$$

$$I_C = I_0 + a I_1 + a^2 I_2 = (18.0075 + j11.7865) \text{ p.u.}$$

$$I_{base_ct} = 1000 * \frac{MVA_{base}}{1.732 * 161 * c_{tr}} = (1000 * 100) / (1.732 * 161 * 300)$$

$$= 1.1954 \text{ A}$$

$$I_a = I_A * I_{base_ct} = (1.4385 - j25.6871) \text{ A} = 25.72 \text{ A at an angle of } -86.79^\circ$$

$$I_b = I_B * I_{base_ct} = (-22.9643 + j11.5978) \text{ A} = 25.72 \text{ A at an angle of } 153.2^\circ$$

$$I_c = I_C * I_{base_ct} = (21.5258 + j14.0893) \text{ A} = 25.72 \text{ A at an angle of } 33.2^\circ$$

Voltages at the primary of the instrument transformer for relay 1 are:

$$V_0 = V_0 + (I_0 * X_{l_line0}) = 0$$

$$V_1 = V_1 + (I_1 * X_{l_line1}) = (0.171 + j0.0464) \text{ p.u.}$$

$$V_2 = V_0 + (I_2 * X_{l_line2}) = 0$$

$$V_A = V_0 + V_1 + V_2 = (0.171 + j0.0464) \text{ p.u.}$$

$$V_B = V_0 + a^2 V_1 + a V_2 = (-0.1257 - j0.1249) \text{ p.u.}$$

$$V_C = V_0 + a V_1 + a^2 V_2 = (-0.0453 + j0.1713) \text{ p.u.}$$

$$V_{base_pt} = \frac{1000 * 161}{1.732 * p_{tr}} = 66.39 \text{ V}$$

$$V_a = V_A * V_{base_pt} = (11.35 - j3.08) \text{ V} = 11.76 \text{ V at an angle of } -15.18^\circ$$

$$V_b = V_B * V_{base_pt} = (-8.34 - j8.29) \text{ V} = 11.76 \text{ V at an angle of } -135.19^\circ$$

$$V_c = V_C * V_{base_pt} = (-3.007 + j11.37) \text{ V} = 11.76 \text{ V at an angle of } 104.81^\circ$$

Similarly, following equations 3.1-3.12 fault currents and voltages for three phase fault at relay 2 are calculated as follows:

Sequence current on the primary of the instrument transformer is:

$$I_0 = 0$$

$$I_1 = (5.7148 - j29.88) * (0.0026 + j0.0464) / ((0.0026 + j0.0464) + (0.0234 + j0.1089))$$

$$= (2.6432 - j8.5815) \text{ p.u.}$$

$$I_2 = 0$$

$$I_A = I_0 + I_1 + I_2 = (2.6432 - j8.5815) \text{ p.u.}$$

$$I_B = I_0 + a^2 I_1 + a I_2 = (-8.7531 + j2.0018) \text{ p.u.}$$

$$I_C = I_0 + a I_1 + a^2 I_2 = (6.11 + j6.5797) \text{ p.u.}$$

$$I_{base_ct} = 1000 * \frac{MVA_{base}}{1.732 * 161 * c_{tr}} = (1000 * 100) / (1.732 * 161 * 300)$$

$$= 1.1954 \text{ A}$$

$$I_a = I_A * I_{base_ct} = (3.1596 - j10.25) \text{ A} = 10.73 \text{ A at an angle of } -72.88^\circ$$

$$I_b = I_B * I_{base_ct} = (-10.4633 + j2.3929) \text{ A} = 10.73 \text{ A at an angle of } 167.11^\circ$$

$$I_c = I_C * I_{base_ct} = (7.3037 + j7.8652) \text{ A} = 10.73 \text{ A at an angle of } 47.11^\circ$$

Voltages at the primary of the instrument transformer for relay 1 are:

$$V_0 = V_0 + (I_0 * X_{l_line0}) = 0$$

$$V_1 = V_1 + (I_1 * X_{l_line1}) = (0.6651 + j0.0148) \text{ p.u.}$$

$$V_2 = V_0 + (I_2 * X_{l_line2}) = 0$$

$$V_A = V_0 + V_1 + V_2 = (0.6651 + j0.0148) \text{ p.u.}$$

$$V_B = V_0 + a^2 V_1 + a V_2 = (-0.3454 - j0.5686) \text{ p.u.}$$

$$V_C = V_0 + a V_1 + a^2 V_2 = (-0.3197 + j0.5834) \text{ p.u.}$$

$$V_{base_pt} = \frac{1000 * 161}{1.732 * p_{tr}} = 66.39 \text{ V}$$

$$V_a = V_A * V_{base_pt} = (44.16 - j0.983) \text{ V} = 44.17 \text{ V at an angle of } -1.27^\circ$$

$$V_b = V_B * V_{base_pt} = (-22.93 - j37.75) \text{ V} = 44.17 \text{ V at an angle of } -121.27^\circ$$

$$V_c = V_C * V_{base_pt} = (-21.22 + j38.73) V = 44.17 V \text{ at an angle of } 118.72^\circ$$

Table 3.1: Fault input values at relay 1.

Three Phase Fault			Single Phase to Ground Fault	
	Magnitude (Ampere)	Angle	Magnitude (Ampere)	Angle
la	25.7274	-86.79	15.43	-86.79
lb	25.7274	153.2	0	0
lc	25.7274	33.2	0	0
Va	11.76	-15.18	11.76	-15.18
Vb	11.76	-135.19	80.61	-133.23
Vc	11.76	104.81	78.83	134.45

Line to Line Fault			Double Line to Ground Fault	
	Magnitude (Ampere)	Angle	Magnitude (Ampere)	Angle
la	0	0	0	0
lb	22.27	-176.79	22.95	169.3
lc	22.27	3.2	22.95	17.1
Va	66.39	0	82.12	0.6144
Vb	37.19	-164.67	11.76	-135.19
Vc	32.07	162.14	11.76	104.81

Table 3.2: Fault input values at relay 2.

Three Phase Fault			Single Phase to Ground Fault	
	Magnitude (Ampere)	Angle	Magnitude (Ampere)	Angle
la	10.7337	-72.88	6.44	-72.88
lb	10.7334	167.11	0	116.56
lc	10.7334	47.11	0	116.56
Va	44.17	-1.27	44.17	-1.27
Vb	44.17	-121.27	72.88	-120.37
Vc	44.17	118.72	69.77	132.2

Line to Line Fault		Double Line to Ground Fault		
	Magnitude (Ampere)	Angle	Magnitude (Ampere)	Angle
Ia	0	0	0	75.96
Ib	9.2954	-162.88	9.5757	-176.77
Ic	9.2954	17.11	9.5757	31.01
Va	66.39	5	72.83	6.08
Vb	53.32	-129.51	44.17	-121.27
Vc	47.83	132.34	44.17	118.72

CHAPTER 4

OMICRON CMC 256-3 AND RUGGED COM SWITCH SET UP FOR TESTING

THE RELAY

OMICRON SET UP

The OMICRON test set is used to supply the measured values of currents and voltages to the relay to check for the proper operation of the relay. The OMICRON Test Universe V2.22 SR 1 software was used for the settings of OMICRON and sending currents and voltages. The complete steps to set the OMICRON test set are shown through the aid of Figures below.

The connection diagram of the two OMICRONS for simulating both ends of transmission line is shown in Figure 4.1. Auxiliary DC supply is used to simulate the breaker in the relay. Binary inputs and outputs can be enabled and set through the Hardware Configuration window available from the toolbar.

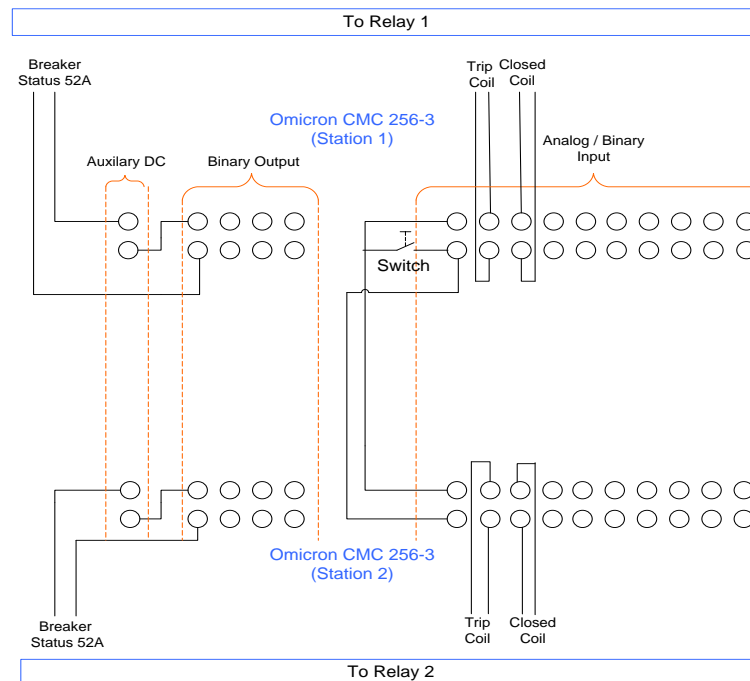

Figure 4.1: Connection Diagram for OMICRON Test Set

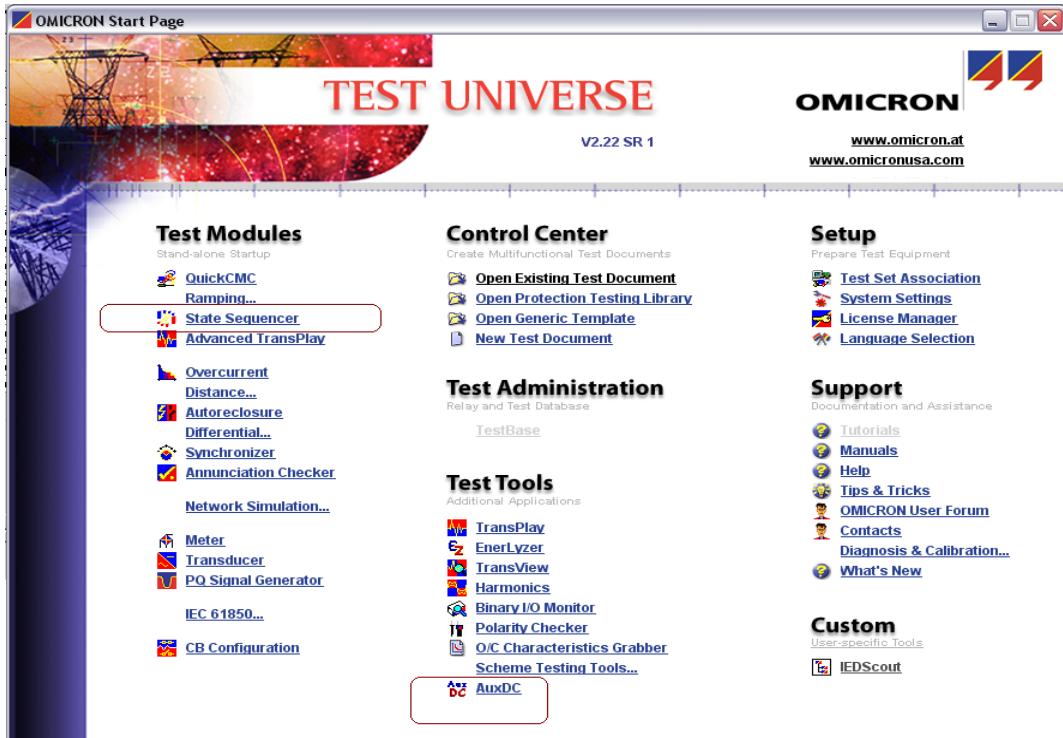

Figure 4.2: The OMICRON Test Universe Home page.

Figure 4.2 shows the quick tabs for state sequence and auxiliary DC.

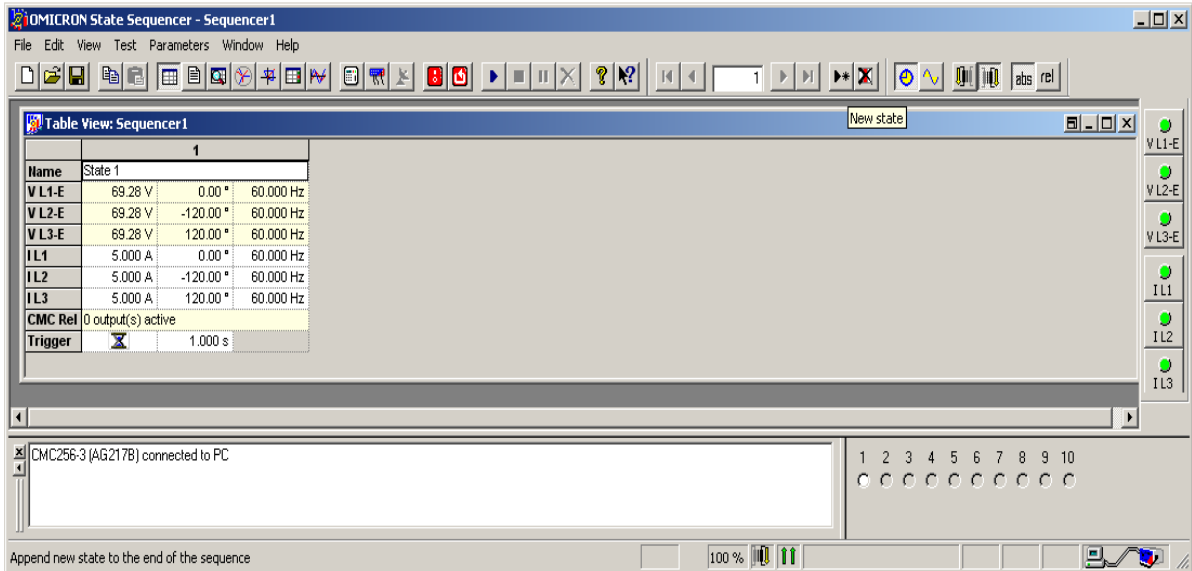

Figure 4.3: State Sequence Window

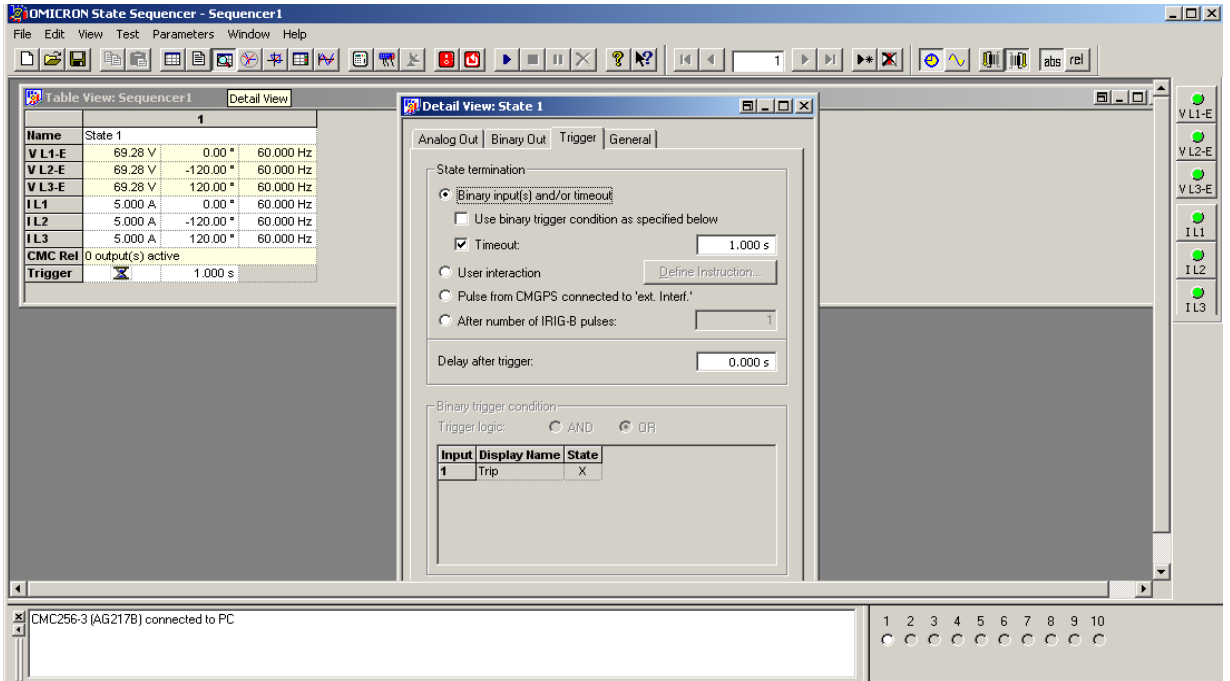

Figure 4.4: Detail View Window

Figure 4.3 shows the state sequencer window with one state activated and Figure 4.4 shows the detail view for the state selected. Detail View window helps to make settings for the triggering of the state. The triggering could be either timeout or a binary trigger. For binary trigger, binary inputs need to be configured.

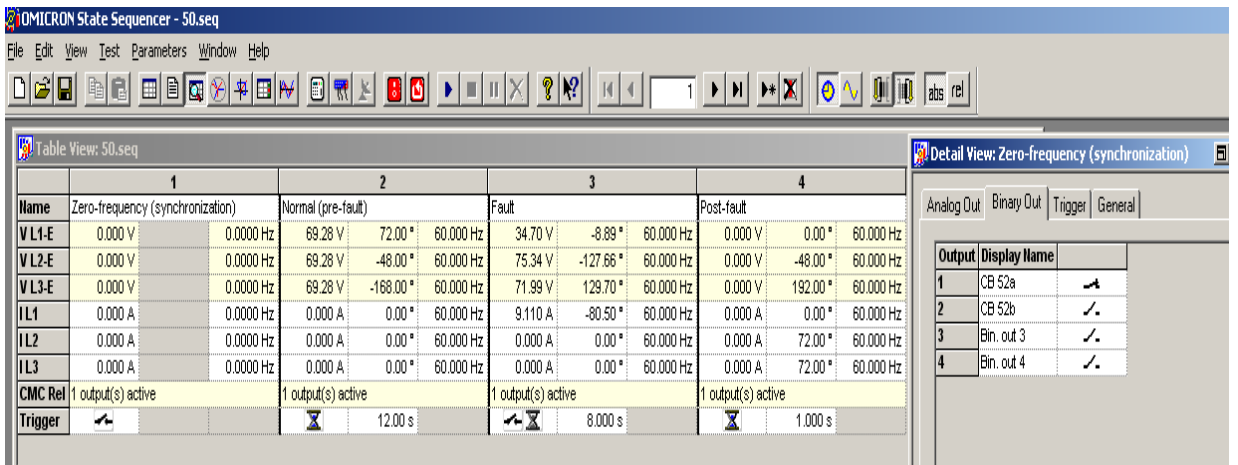

Figure 4.5: Four states selected for testing the line

Three states - pre-fault, fault and post fault states - are created through State Sequencer from OMICRON Test Universe software. Each state can be independently set for triggering using binary input and binary outputs. Since the relays at both ends of the transmission line should see the fault at the same time, OMICRON test sets should be configured in such a way that the pre-fault state gets triggered at the same time, for both OMICRONS. So, a synchronization state was added before the pre-fault state which provides zero current and zero voltages.

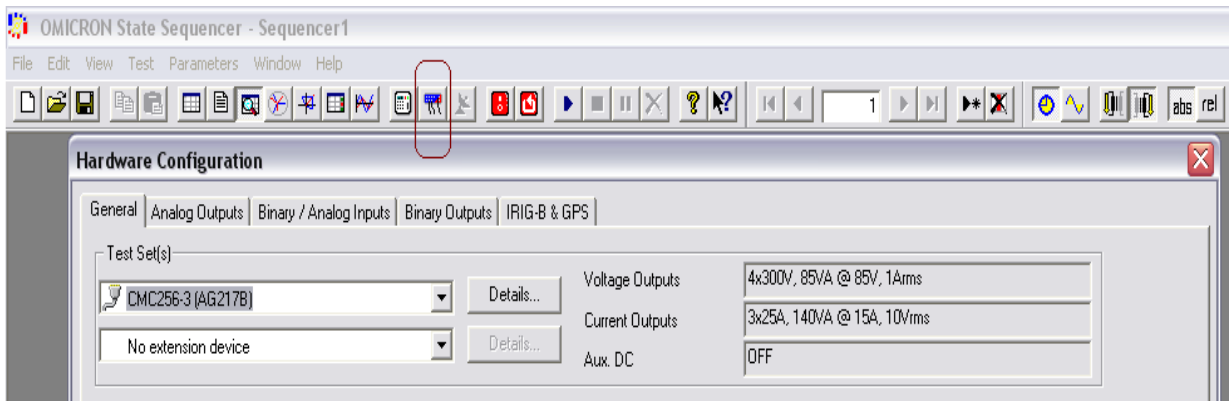

Figure 4.6: Hardware configuration selection.

Hardware Configuration			CMC256-3 AG217B																
			Binary		Binary		Binary		Binary		Binary		Binary		Binary		Binary		
Function	Test Module Input Signal	Display Name	1+	1-	2+	2-	3+	3-	4+	4-	5+	5-	6+	6-	7+	7-	8+	8-	9
Potential Free			<input checked="" type="checkbox"/>	<input checked="" type="checkbox"/>	<input checked="" type="checkbox"/>	<input checked="" type="checkbox"/>	<input checked="" type="checkbox"/>	<input checked="" type="checkbox"/>	<input checked="" type="checkbox"/>	<input checked="" type="checkbox"/>	<input checked="" type="checkbox"/>	<input checked="" type="checkbox"/>	<input checked="" type="checkbox"/>	<input checked="" type="checkbox"/>	<input checked="" type="checkbox"/>	<input checked="" type="checkbox"/>	<input checked="" type="checkbox"/>	<input checked="" type="checkbox"/>	<input checked="" type="checkbox"/>
Nominal Range																			
Clamp Ratio																			
Threshold																			
Trip	Trip	Trip	X		X														
Bin. in 3	Bin. in 3	Bin. in 3					X												
Trip F	Bin. In. 3	Bin. In. 3					X												
Start	Bin. In. 4	Bin. In. 4						X											
Start L1	Bin. In. 5	Bin. In. 5							X										
Start L2	Bin. In. 6	Bin. In. 6								X									
Start L3	Bin. In. 7	Bin. In. 7									X								
Forward dir.	Bin. In. 8	Bin. In. 8										X				X			
Reverse dir.	Bin. In. 9	Bin. In. 9											X						
Close Cmd	Bin. In. 10	Bin. In. 10																	X
Bin. in	Bin. In. 11	Bin. In. 11																	
Bin. in 1	Bin. In. 12	Bin. In. 12																	
Bin. in 2																			
Bin. in 3																			

Figure 4.7: Settings Binary Inputs

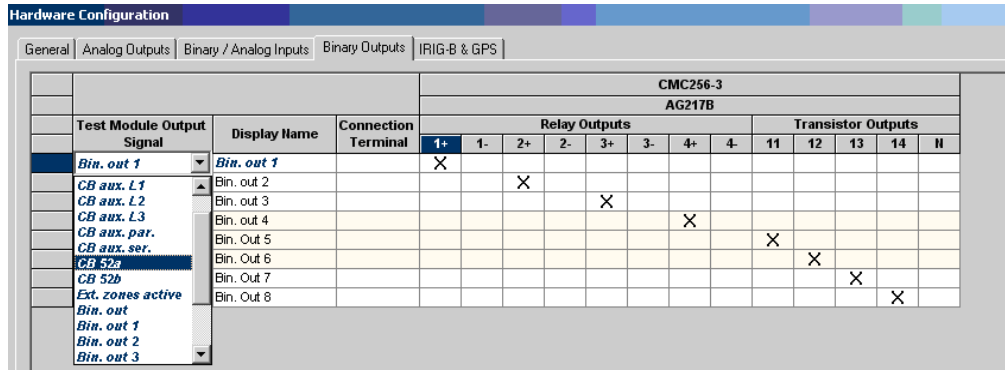

Figure 4.8: Setting Binary Outputs

Figure 4.6, 4.7 and 4.8 shows how to select the hardware configuration window from the toolbar. The binary inputs and outputs can be set using the drop down menu.

COMMUNICATION SWITCH

The basic need of IEC-61850 is to communicate on Ethernet through a GOOSE message. This is achieved by having a switch from which all the relays were made to communicate. The Rugged Com Switch RS-1600T was used for this purpose.

Rugged Com switch has 16 ethernet ports in its front panel out of which fourteen are 10/100 Base TX and two are 100 Base FX. The RS 232 port is provided at the back panel. A straight through serial cable with DB-9 connector is used.

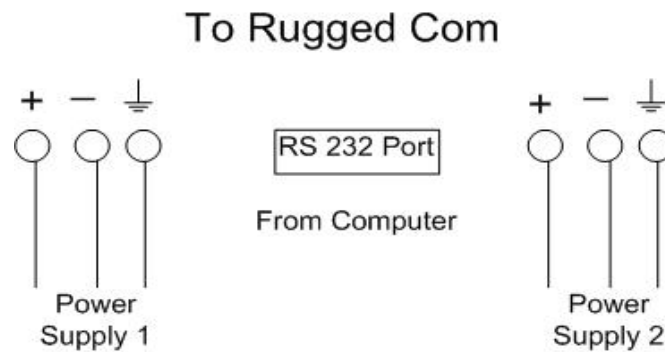

Figure 4.9: Backpanel view of Rugged Com Switch

CHAPTER 5

INSTALLATION SETTINGS

The relay has “Relay Name” setting that specifies the unique identification name for the relay. User can also give description of the loaded settings at a particular time through “User Configuration Name”. Also, the date when the settings were last set can be set using the “User Configuration Date”. Relay setting allows the relay to safeguard against the installation of a device without any entered settings. The D90^{Plus} will not allow signaling of any output relay until this setting is set as “Programmed”. The self test on front panel of relay displays “Unit not Programmed” until the relay is put into programmed state.

AC INPUT MODULES

An AC Input module has 12 inputs and are numbered through 1 to 12.

Channels 1, 2, 3 form a three phase current input

Channels 4, 5, 6 form a second set of three phase current inputs

Channel 7 is a single phase current input

Channels 8 and 9 are single phase voltage inputs

Channels 10, 11, 12 form three phase voltage inputs.

CURRENT INPUT

Phase CT ratio: It specifies the phase CT ratio for the corresponding current input and is used for calculation of primary metering values.

Phase CT secondary: It specifies the secondary rating of the CT. It can be set for 5 or 1 amps.

Current cut-off level: Current values of 1-2% of rated value are very susceptible to noise. User can specify cut-off value for current in D90^{Plus}. If value of current is below the cut-off, it is substituted with zero.

VOLTAGE INPUT

Phase VT connection: Delta or Wye connections are used for phase VT connections.

Phase VT secondary: It specifies the secondary voltage value for the VT.

Phase VT ratio: Range: 1-2400V in steps of 0.001. It specifies the primary to secondary ratio of the voltage transformer.

Auxiliary VT connection: Range: Vag, Vbg, Vcg, Vab, Vbc, Vca, Vn. It specifies the auxiliary VT connection type for the corresponding voltage input.

Auxiliary VT secondary: It specifies the secondary voltage of auxiliary VT.

Auxiliary VT ratio: Range: 1-2400V in steps of 0.001. It specifies the auxiliary VT ratio for corresponding voltage.

Voltage cut-off level: Voltage values of 1-2% of rated value are very susceptible to noise. User can specify cut-off value for voltage. If value of voltage is below the cut-off, it is substituted with zero.

POWER SYSTEM FREQUENCY

Nominal frequency: Range: 50 Hz or 60 Hz.

Phase rotation: Range: ABC, ACB. It matches the power system phase and informs the relay of the actual system phase sequence.

SIGNAL SOURCE SETTINGS

Name: Range: upto 20 alphanumeric characters. It specifies the name for the protection source.

Phase CT: Range: None, J1, J4, J1+J4, etc. It selects the phase CT or the sum of phase CT's to represent a protection source. Eg. J1+J4 indicates the sum of each phase from channels J1+J4, scaled to whichever CT has higher ratio.

Ground CT: Range: none, J7

Phase VT: Range: None, J8, J9.

Auxiliary VT: Range: None, J10.

GROUPED PROTECTION ELEMENTS

LINE PICK-UP

A de-energized line can be detected using this setting. Zone 1 extension can be achieved using line pick-up. In present case line pick-up has been disabled.

DISTANCE ELEMENTS

Source: This setting identifies the signal source for all the directional elements.

Memory duration: The setting specifies the time for which a memorized positive-sequence voltage should be used in distance calculations. If the magnitude of actual positive sequence voltage is higher than 10 percent even after this interval expires, then the actual voltage is used. If it is lower then memory voltage is continued to be used.

PHASE DISTANCE

The phase mho distance uses a dynamic 100 percent memory polarized mho characteristic with additional reactance, directional and overcurrent supervising characteristic. There are five phase distance zone settings available.

Function: It enables and disables the phase distance protection feature.

Direction: Relay can be set to look forward, reverse or non-directional using this setting.

Shape: This setting selects the shape of the phase distance function between the mho and quadrilateral characteristics.

Transformer Voltage Connections: Different type of transformer voltage connections can be selected using this setting, eg. Dy1, Dy3, Dy5, etc. For this study, the setting 'None' is chosen.

Transformer Current Connections: Different type of transformer current connections can be selected using this setting, eg. Dy1, Dy3, Dy5, etc. For this study, the setting 'None' is chosen.

Reach: This setting specifies the zone reach for the forward or reverse applications. For the non-directional application, this setting specifies the forward reach of the zone.

RCA: This setting specifies the characteristic angle (or maximum torque angle). It defines the sensitivity of the relay.

Reverse Reach: The reverse reach of non-directional zone is specified by this setting.

Reverse Reach RCA: This setting specifies the characteristic angle of the reverse reach impedance of non-directional zone.

Comparator Limit: The shape of operating angle is defined by this setting. For mho type it gives a lens type shape and a tent type shape for quadrilateral. For mho type, it improves the loading of protective line and for quadrilateral shape it increases the security for faults close to the reach point by adjusting the reactance boundary into a tent shape.

Supervision: The magnitude of line to line current supervises the phase distance elements. If the minimum fault current is sufficiently high, then the supervision pickup

should be set above the maximum full load current, thus preventing the maloperation under VT fuse fail conditions.

Delay: This setting adds delay to the distance elements and implements stepped distance protection. Zone 2 through 5 adds a short dropout delay.

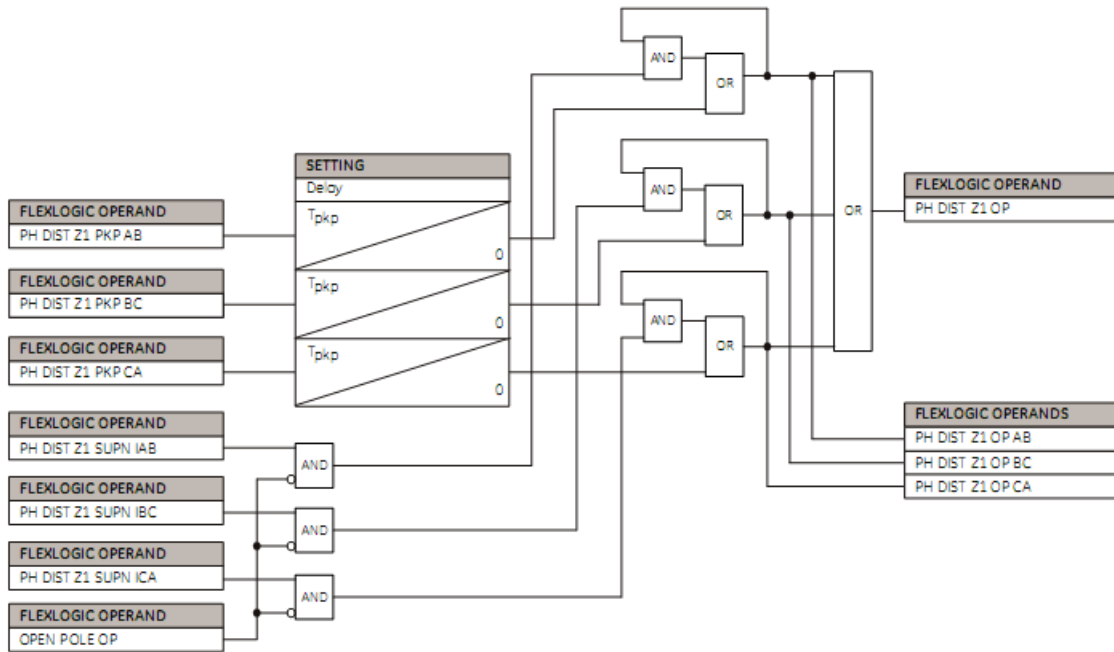

Figure 5.1: Phase distance Zone 1 operation logic [17].

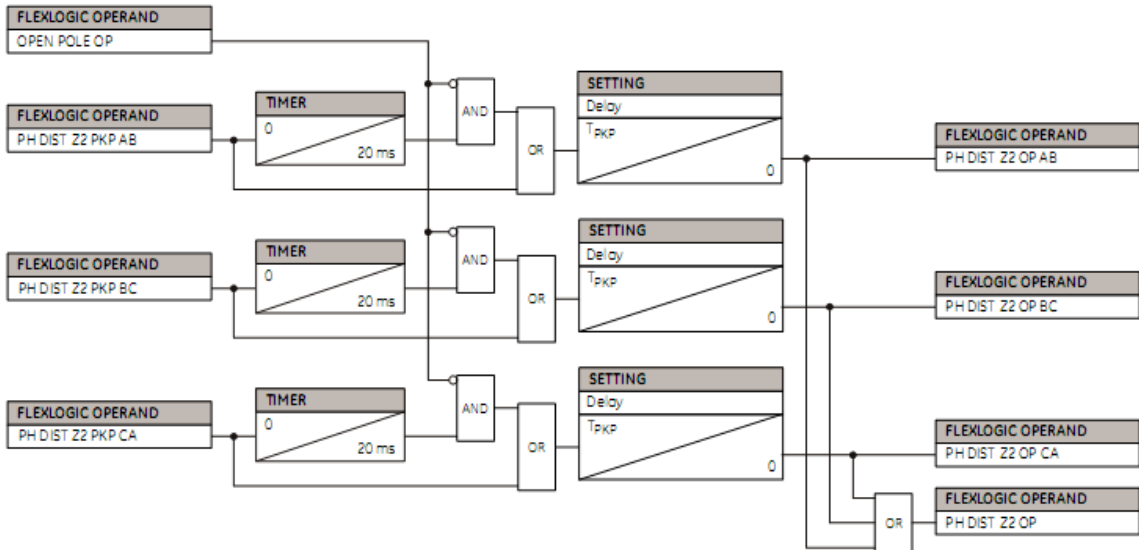

Figure 5.2: Phase distance Zone 2 operation logic [17].

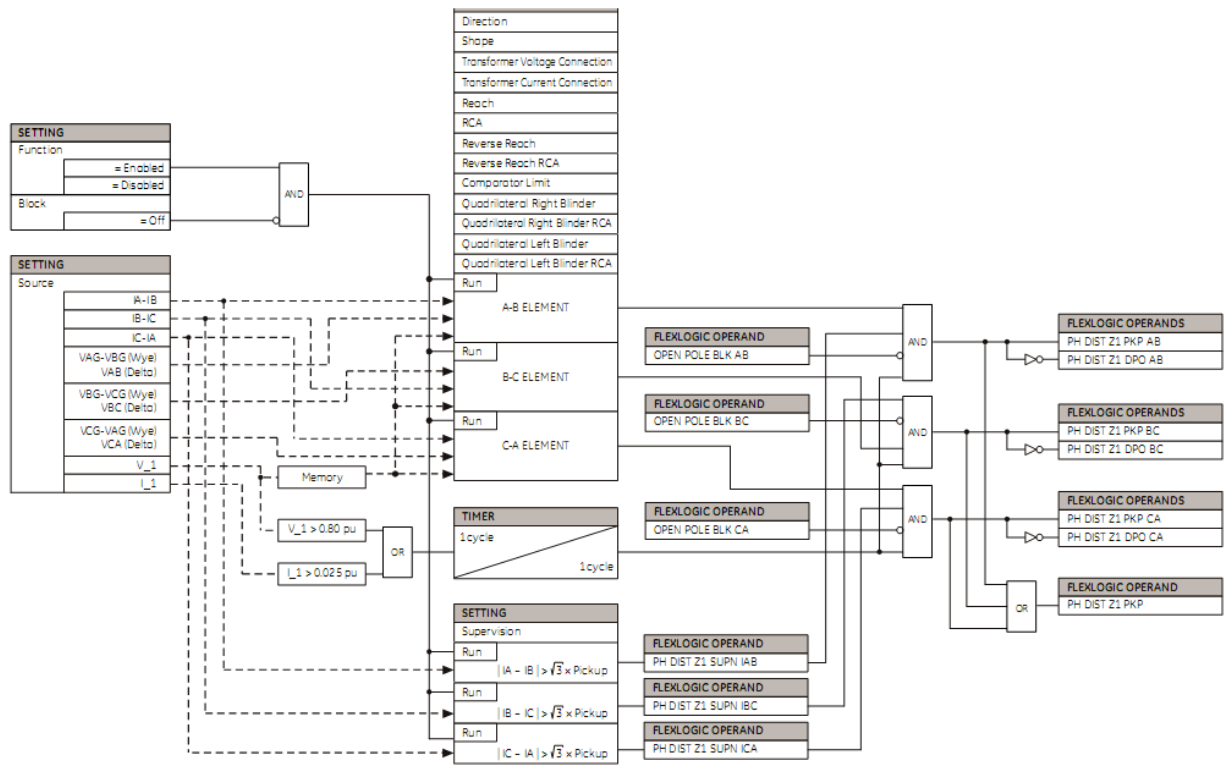

Figure 5.3: Phase distance element scheme logic [17].

GROUND DISTANCE

The ground mho distance function uses a dynamic 100 percent memory polarized mho characteristics with additional reactance, directional, current and phase selection supervising characteristics. The reactance supervision for the mho function uses the zero-sequence current for polarization.

Direction: The ground distance element can be set looking as forward, reverse or non-directional. The forward direction is set by RCA setting and reverse direction is shifted by 180 degrees from that angle.

Shape: This setting selects the shape between mho and quadrilateral characteristics.

Z0/Z1 Magnitude: This setting specifies the ratio of zero sequence and positive sequence impedance required for zero sequence compensation of ground distance elements.

ZO/Z1 Angle: This setting specifies the angle difference between the zero sequence and positive sequence impedance required for zero sequence compensation of ground distance elements.

Reach: This setting specifies the reach of the ground distance element on per zone basis.

RCA: This setting specifies the characteristic angle of the ground distance characteristic for the forward and reverse characteristics.

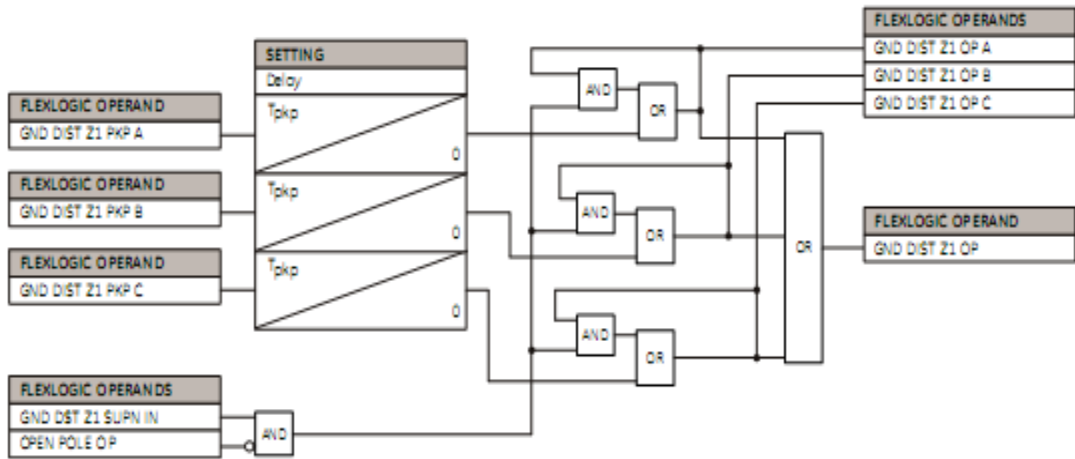

Figure 5.4: Ground distance zone 1 operation logic [17].

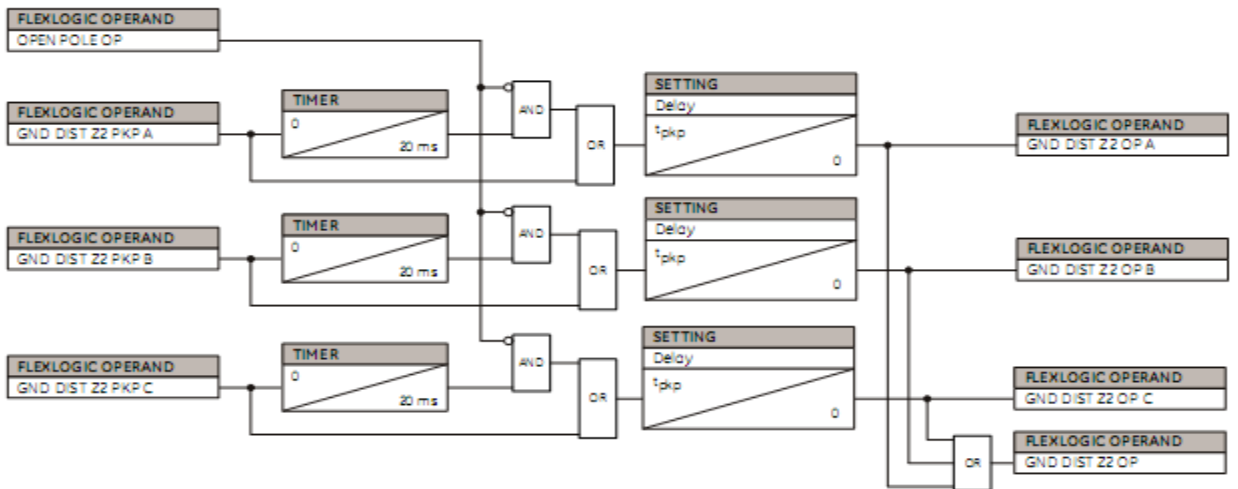

Figure 5.5: Ground distance zone 2 operation logic [17].

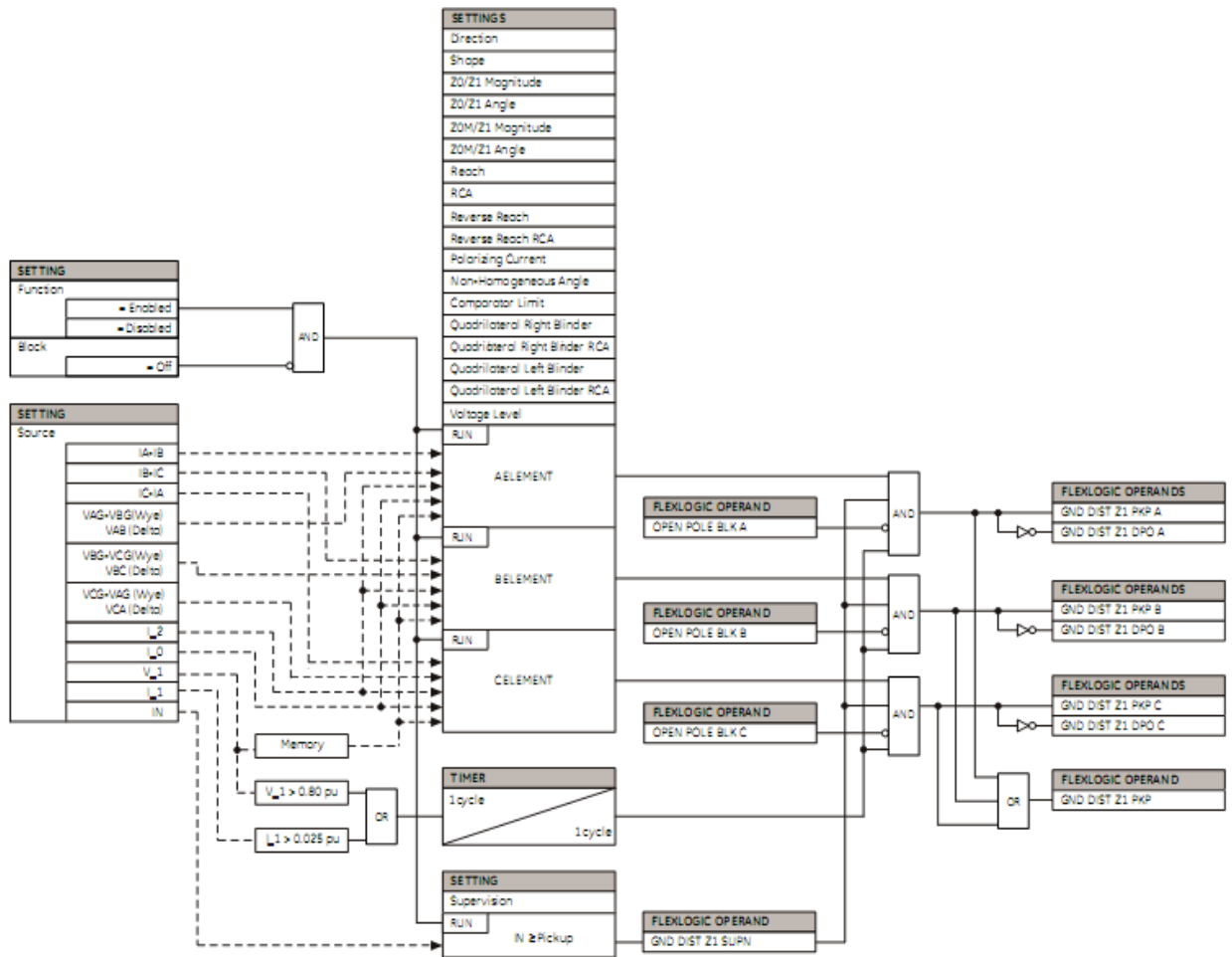

Figure 5.6: Ground distance zone 1 scheme logic [17].

PHASE INSTANTANEOUS OVERCURRENT ELEMENT

Phase instantaneous element may be used as an instantaneous element with no intentional delay.

Source: This setting selects the signal source for the phase instantaneous overcurrent protection element.

Pickup: This setting specifies the phase instantaneous overcurrent pickup level in per unit values.

Delay: This setting delays the assertion of the phase instantaneous overcurrent element. It helps to achieve timing coordination with other elements and relays.

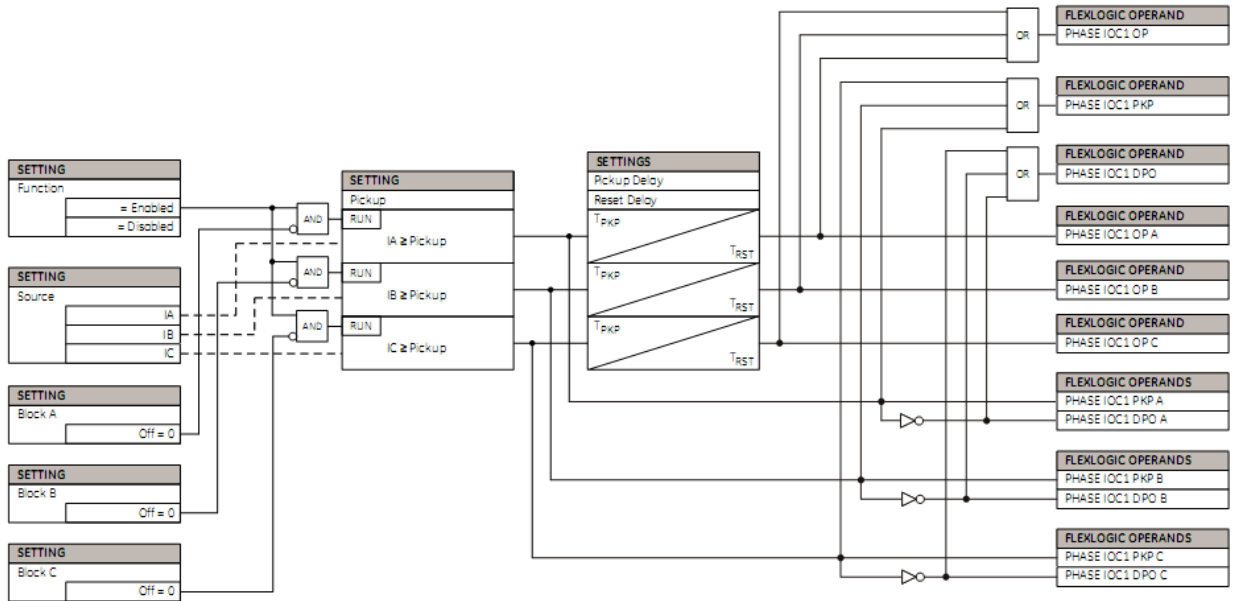

Figure 5.7: Phase instantaneous overcurrent scheme logic [17]

Reset Delay: This setting specifies a delay for the reset of the phase instantaneous overcurrent element between the operate output state and return to logic zero after the input passes outside the defined pickup range. This setting is used to ensure that the relay output contacts are closed long enough to ensure reception by downstream equipment.

CONTROL

PERMISSIVE OVERREACH TRANSFER TRIP (POTT)

POTT uses the overreaching zone 2 distance element to compare the direction to a fault at both terminals of the line. The output operands (POTT TX1 through POTT TX4) generated are used to transmit signal to the remote end. The output operands must be configured with other relay input operands.

Function: This setting must be “Enabled” while using the POTT scheme.

RX Pickup Delay: This setting is used to cope with the spurious signals that can be received simultaneously with zone 2 pickup. The delay added should be longer than the longest spurious transmitted (TX) signal. The delay will increase the response time of the POTT scheme.

Communication bits: This setting specifies number of bits (1,2 or 4) of the communication channel available for the POTT scheme. With 1 bit selection, the scheme send permissive overreach transfer trip command on bit 1 (the POTT TX1 operand) and responds to the direct trip command received on bit 1 (the RX1 setting). The scheme uses the local fault type identification provided by the phase selector to assert the trip commands (POTT TRIP A, POTT TRIP B, POTT TRIP C, POTT TRIP 3P).

RX1, RX2, RX3, RX4: This setting selects the Flex Logic Operand that represents the receive signal for the scheme.

In single bit applications RX1 must be used.

In two bit applications RX1 and RX2 must be used.

In four bit applications RX1 through RX4 are used.

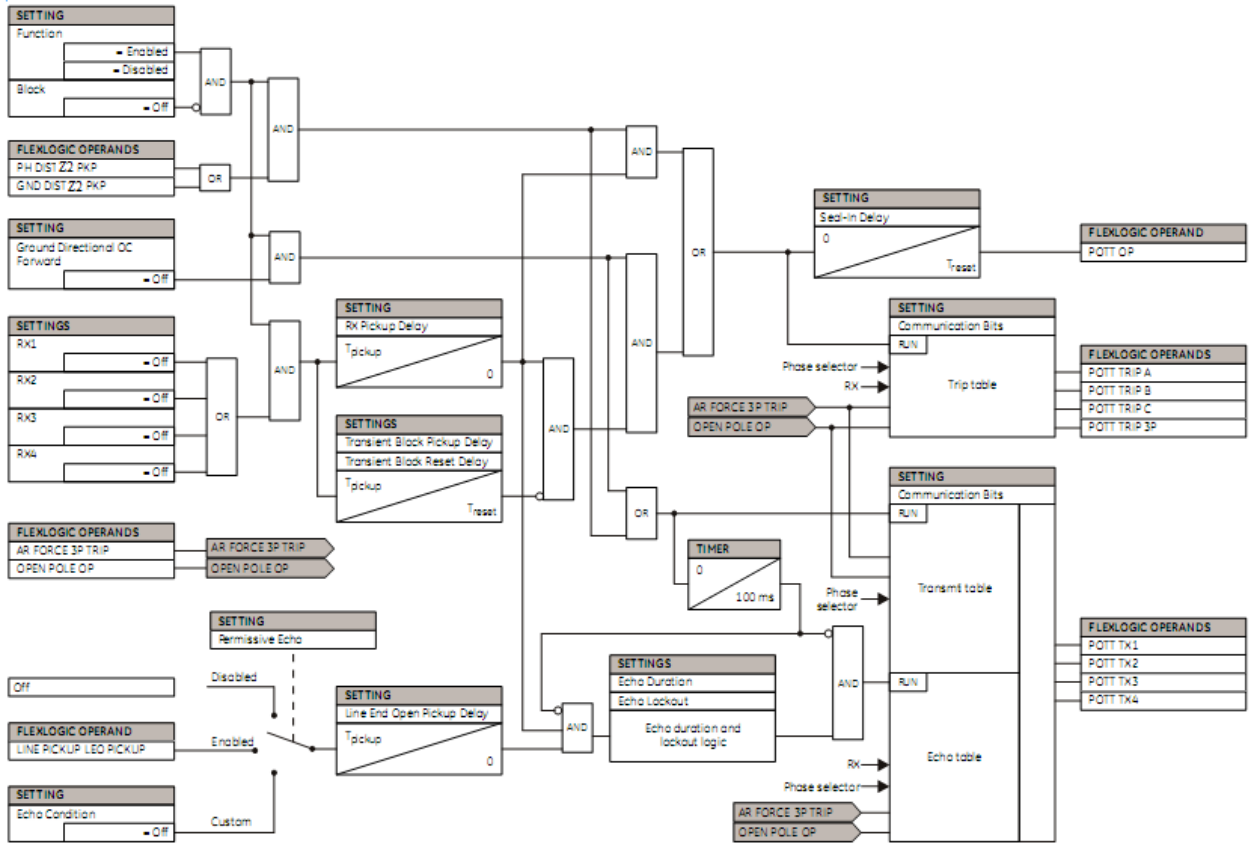

Figure 5.8: Permissive Overreach Transfer Trip Scheme Logic [17]

TRIP OUTPUT

Trip output element collect trip requests from protection elements and other inputs to generate output operands to initiate trip operations. If programmed, then, three pole trip initiate reclosure of breaker, whereas the single pole trip always initiate reclosure of breaker.

Trip mode: This setting selects the mode of operation from “3 pole only”, “3 pole and 1 pole” and “1 pole”.

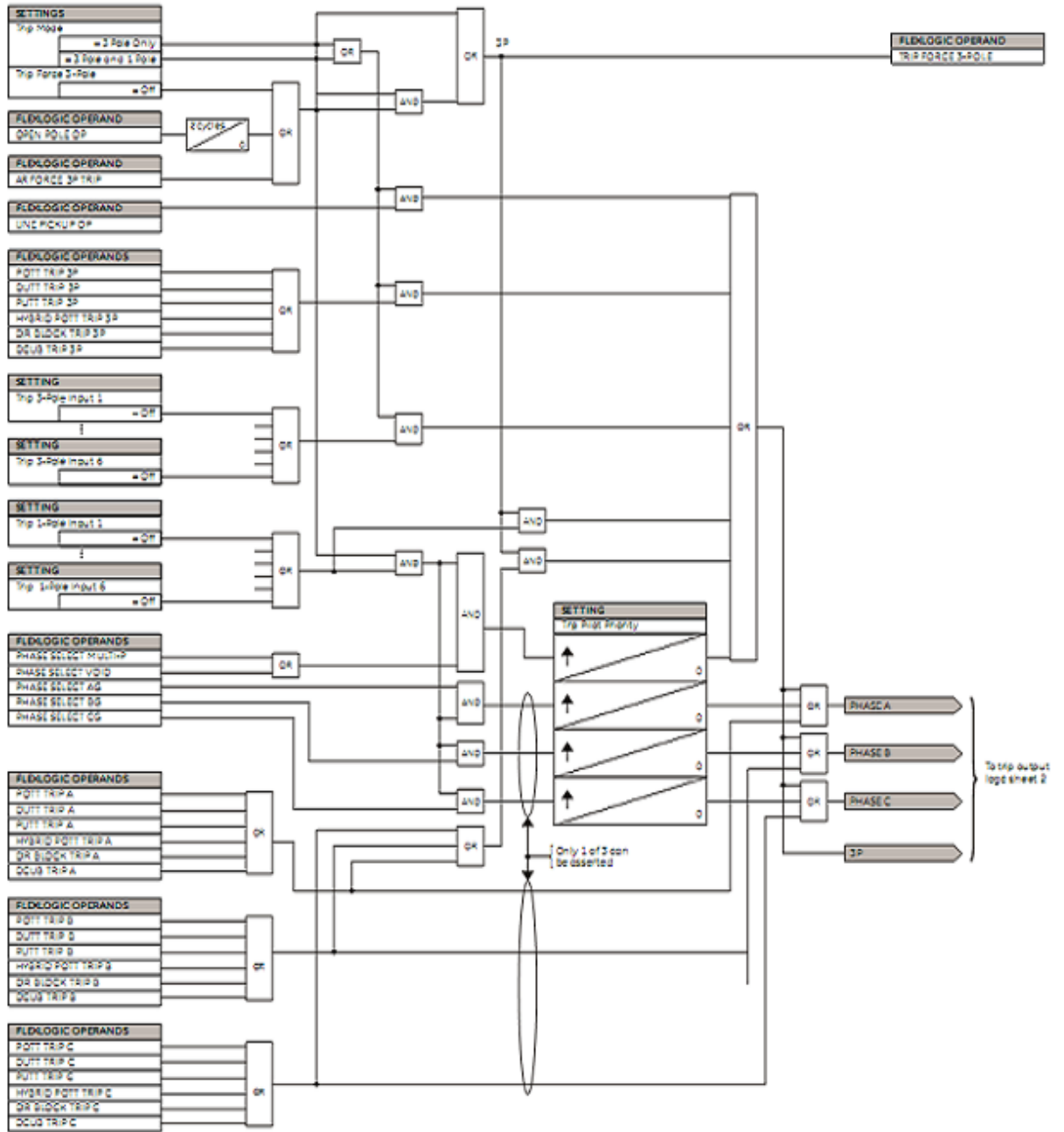

Figure 5.9: Trip output scheme logic sheet1 [17].

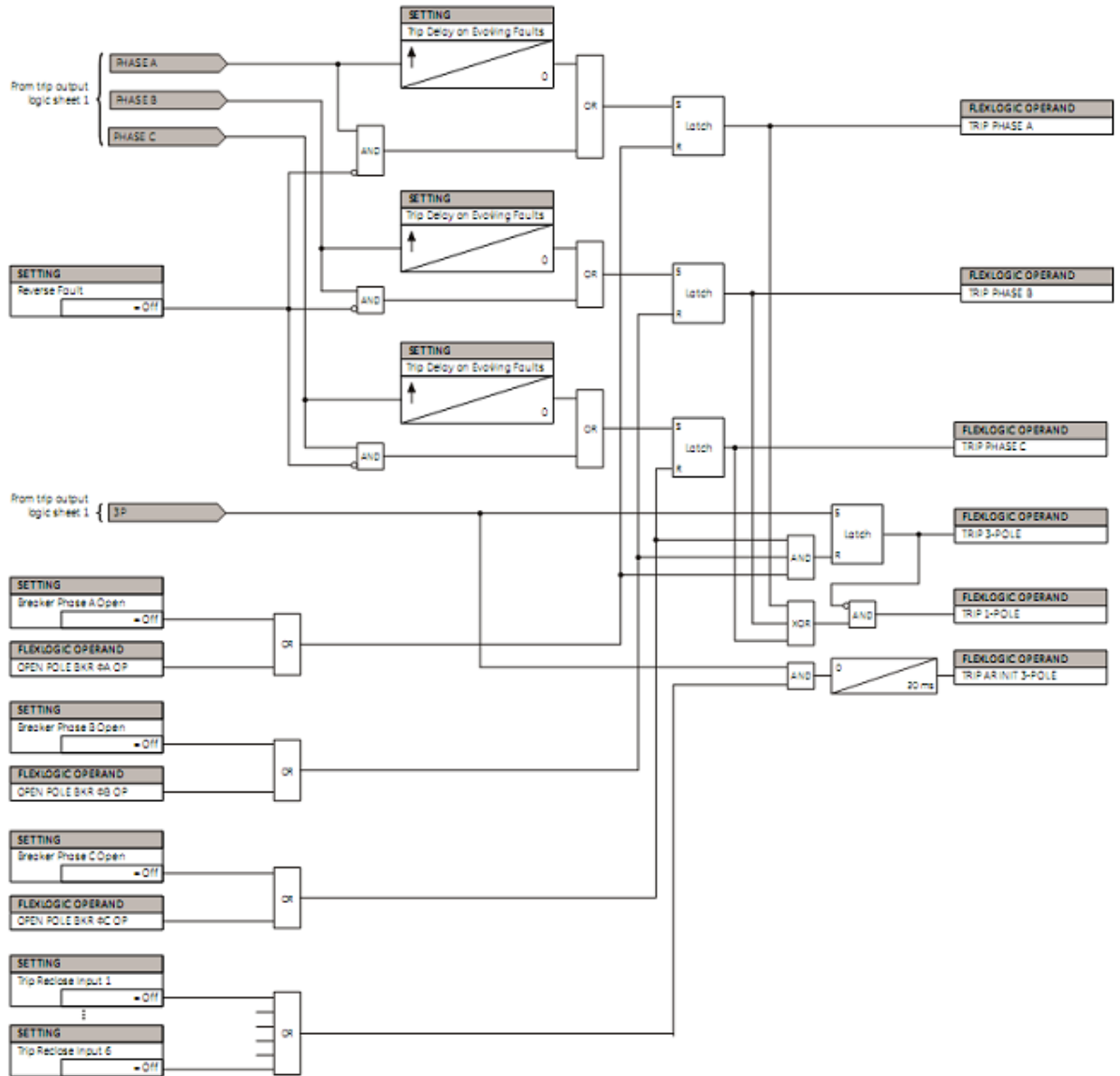

Figure 5.10: Trip output scheme logic sheet 2 [17].

Trip 3 pole input (1 through 6): These settings select operand that is required to generate three pole trip operation. If more than six inputs are required then OR gate is used.

Trip 1 pole input (1 through 6): These settings select operand that is required to generate one pole trip operation. If more than six inputs are required then OR gate is used.

Trip reclose input (1 through 6): This setting selects an operand representing a fault condition that is desired to initiate three pole reclosing. If more than six inputs are required then OR gate is used.

Trip force 3-pole: This setting selects an operand that will force an input selected for single pole operation to produce a three pole operation.

BREAKERS

The logic settings for breaker control serve as interface for opening and closing of breaker from protection and automation functions. The breaker function is enabled and rest of the settings were left as default.

DIGITAL FAULT RECORDER

The digital fault recorder (DFR) performs following four functions:

- 1) Event recorder provides a time stamped record of operation of breakers, protection elements and alarms.
- 2) Fault recorder records the fault type, magnitude and duration of fault.
- 3) Transient recorder records analog and digital signals for short duration events with high resolution.
- 4) Disturbance recorder records long duration events like power swings and voltage sags, with 1 sample per cycle resolution.

FAULT REPORT

Positive sequence (Z_1) magnitude: This setting specifies the magnitude of positive sequence impedance of transmission line in secondary ohms.

Positive sequence (Z_1) angle: This setting defines the angle of the positive sequence impedance of transmission line.

Zero sequence (Z_0) magnitude: This setting specifies the magnitude of zero sequence impedance of transmission line in secondary ohms.

Zero sequence (Z_0) angle: This setting defines the angle of the zero sequence impedance of transmission line.

Line length Units: This setting selects the units for length i.e. km or miles, of transmission line.

Line length: This setting specifies the length of the transmission line in the line length units selected.

CHAPTER 6

RESULTS

The system was tested for four fault types: single phase to ground, three phase fault, line to line fault and double line to ground fault. Faults were simulated at 10 percent distance from Bus G as shown in Figure 3.1. GOOSE message carrying POTT Trip signal were exchanged between both ends and were observed to trip the breaker before the zone2 time delay expiration.

SINGLE LINE TO GROUND FAULT

Relay 1: Ground Distance Zone 1 and Zone 2 were expected to pick up, thus sending GOOSE POTT message and Zone 1 should operate in relay 1. Relay 1 behaved as expected.

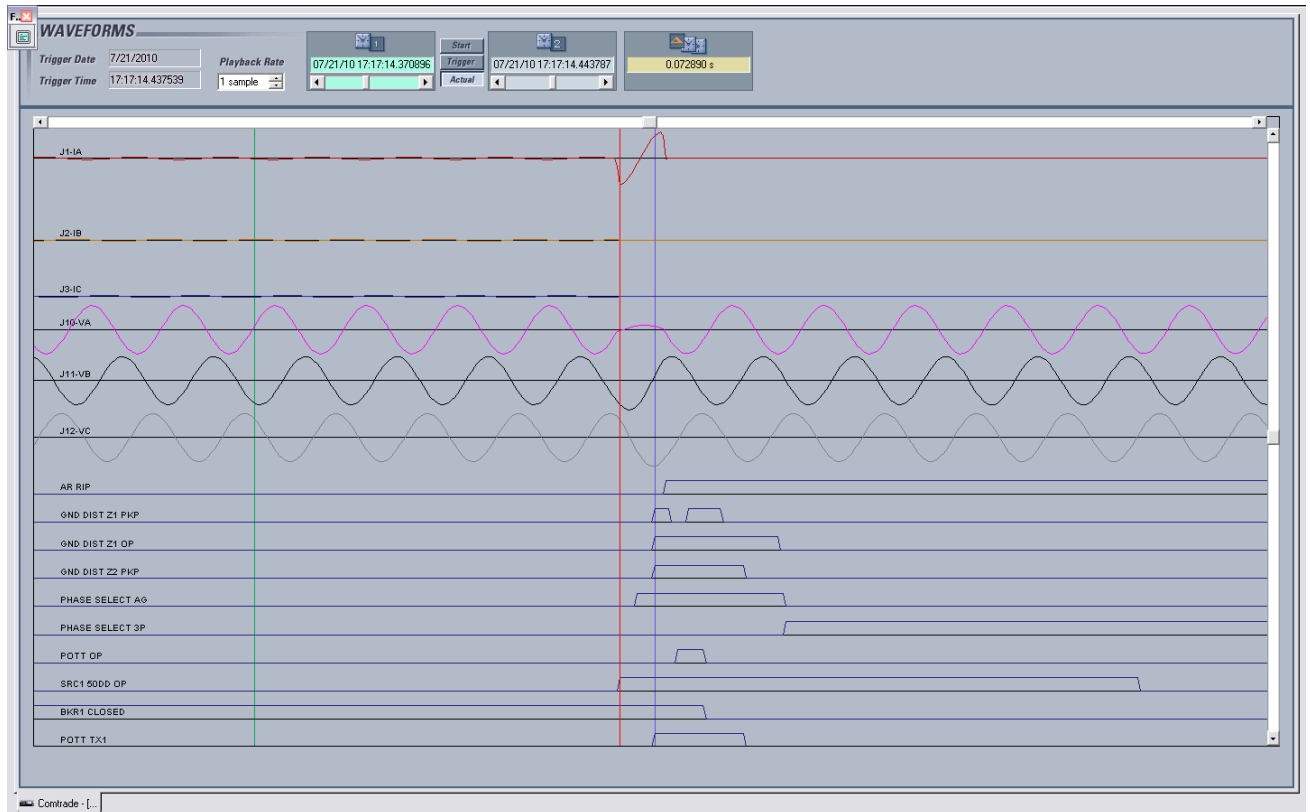

Figure 6.1: Relay 1 oscillography for single line to ground fault

Time taken by relay 1 to send the POTT Transmit signal using time stamps is

$$= (\text{POTT TX trigger time} - \text{Disturbance using detector trigger time})$$

$$= (0.005728 - 0.0) \text{ seconds}$$

$$= 5.728 \text{ millisecond}$$

Ground Distance Zone 2 picks up in Relay 2 and transmits a GOOSE POTT. Relay 2 is expected to receive a POTT from Relay 1 and should operate. Relay 2 operates as expected. POTT operates as soon as remote input GOOSE message from relay 1 is received.

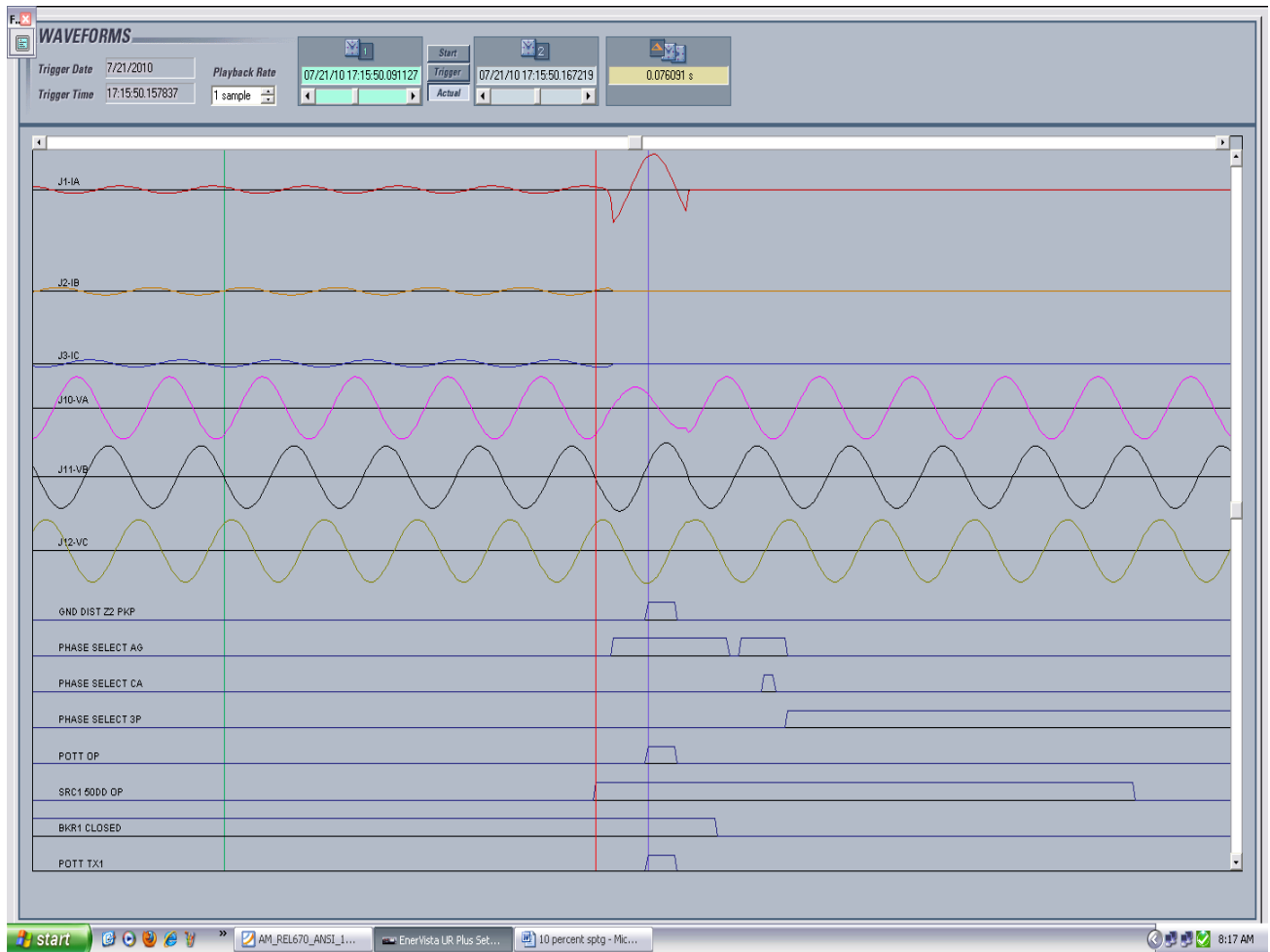

Figure 6.2: Relay 2 oscillography for single line to ground fault

Time taken by relay 2 to send the POTT Transmit signal using time stamps is

$$\begin{aligned}
 &= (\text{POTT TX trigger time} - \text{Disturbance using detector trigger time}) \\
 &= (0.008859 - 0.0) \text{ seconds} \\
 &= 8.859 \text{ millisecond}
 \end{aligned}$$

THREE PHASE FAULT

Relay 1: Phase distance zone 1 and zone 2 are expected to pick up and should send a GOOSE POTT trip signal to relay 2. Zone 1 should trip instantaneously. Relay 1 responds as expected. A three phase Phase Distance Zone 1 is asserted and a GOOSE POTT is transmitted.

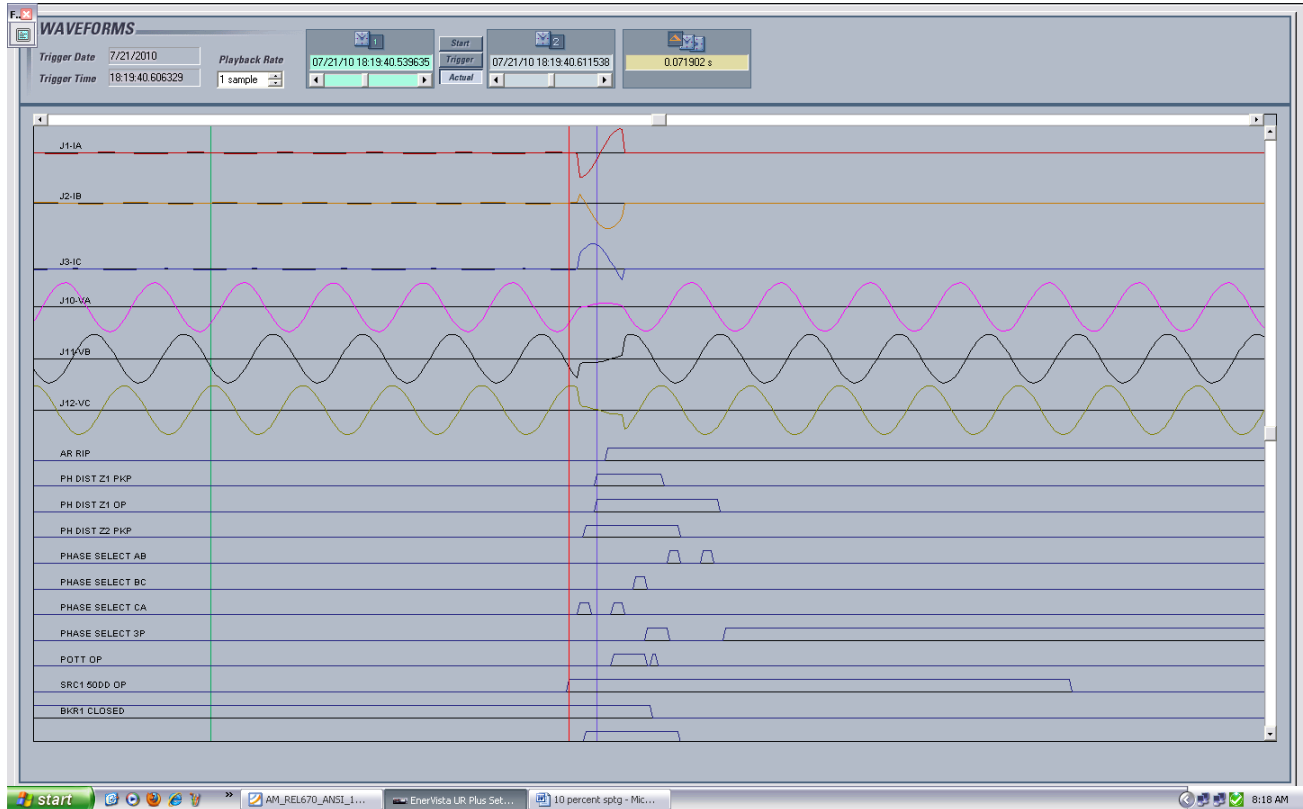

Figure 6.3: Relay 1 oscillography for three phase fault

Time taken by relay 1 to send the POTT Transmit signal using time stamps is

$$\begin{aligned} &= (\text{POTT TX trigger time} - \text{Disturbance using detector trigger time}) \\ &= (0.002605 - 0.0) \text{ seconds} \\ &= 2.605 \text{ millisecond} \end{aligned}$$

Relay 2: Phase Distance Zone 2 should pick up and transmit a POTT trip message. Relay 2 operates as expected picking up Phase Distance Zone 2 and tripping as soon as remote GOOSE POTT is received without waiting for zone 2 time delay to get over.

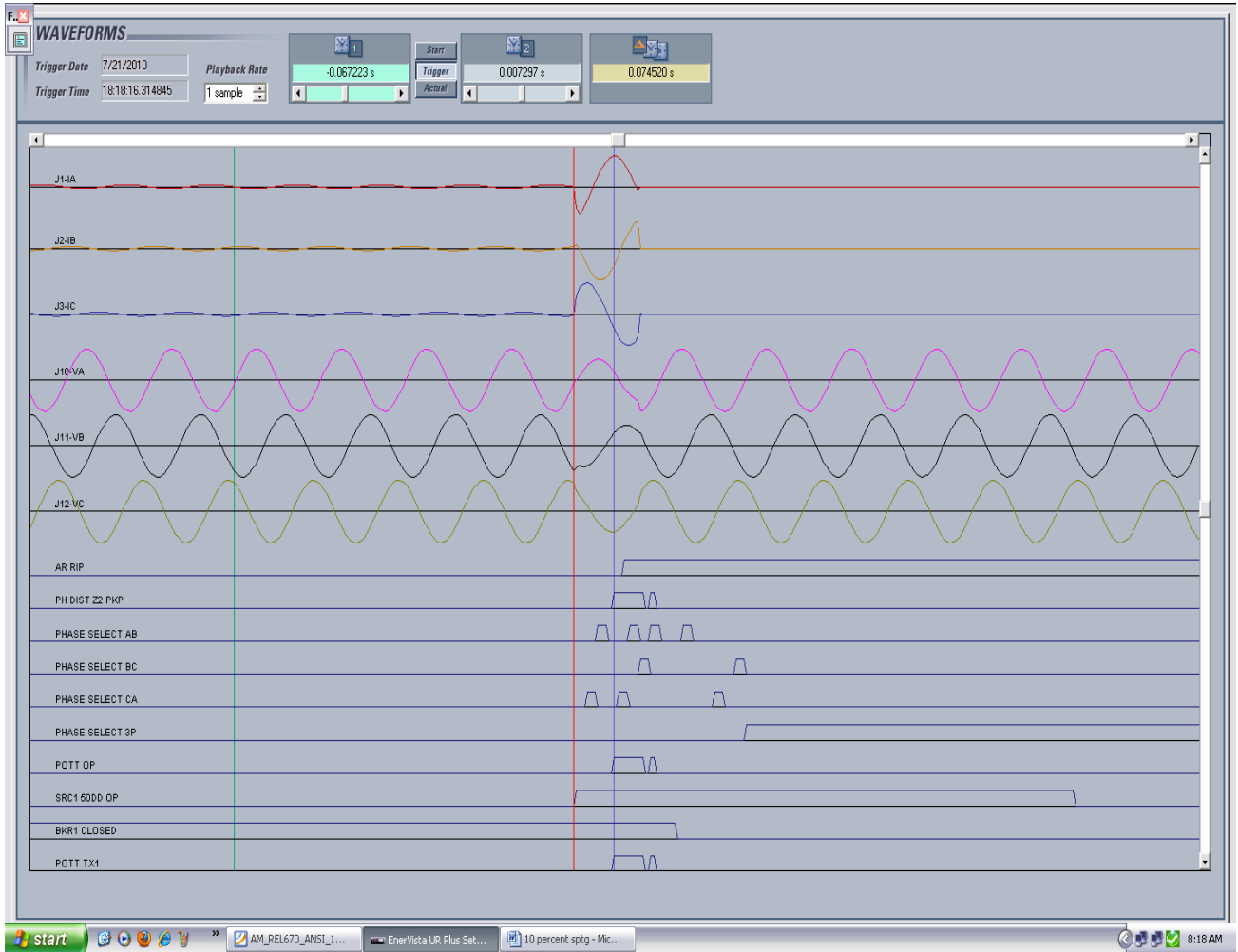

Figure 6.4: Relay 2 oscillography for three phase fault

Time taken by relay 2 to send the POTT Transmit signal using time stamps is

$$\begin{aligned}
 &= (\text{POTT TX trigger time} - \text{Disturbance using detector trigger time}) \\
 &= (0.006776 - 0.0) \text{ seconds} \\
 &= 6.776 \text{ millisecond}
 \end{aligned}$$

LINE TO LINE FAULT

Relay 1 is expected to pick up at Phase Distance Zone 1, Zone 2 and send a GOOSE

POTT message. It should assert zone 1 operate. Relay 1 passed the expectations.

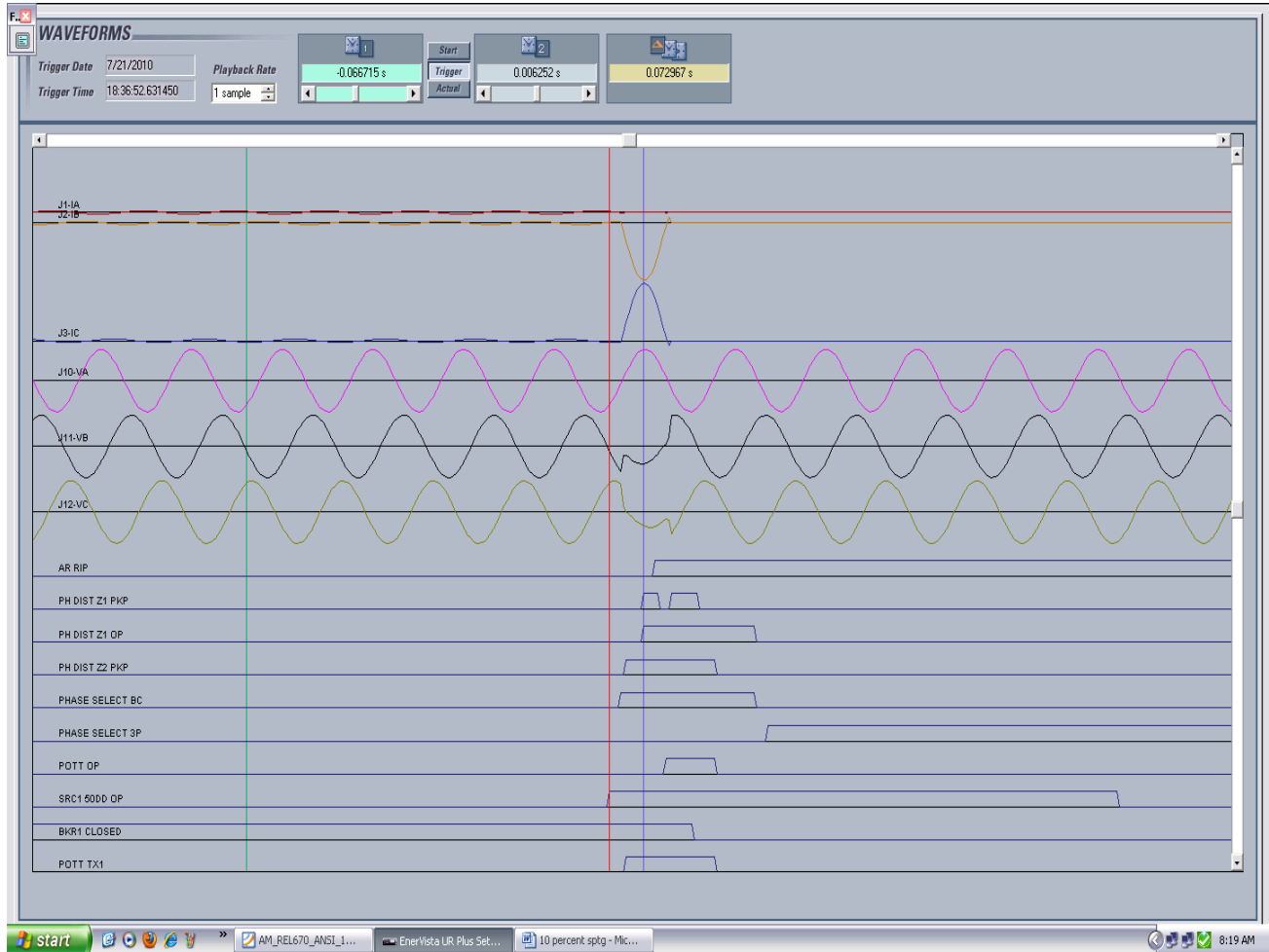

Figure 6.5: Relay 1 oscillography for line to line fault

Time taken by relay 1 to send the POTT Transmit signal using time stamps is

$$= (\text{POTT TX trigger time} - \text{Disturbance using detector trigger time})$$

$$= (0.002604 - 0.0) \text{ seconds}$$

$$= 2.604 \text{ millisecond}$$

Relay 2 should pick up for Zone 2 and transmit a GOOSE POTT signal. It should trip for the Zone 2 or POTT. Relay 2 responded as expected, picking up for Zone 2 and operating at reception of remote input POTT trip signal.

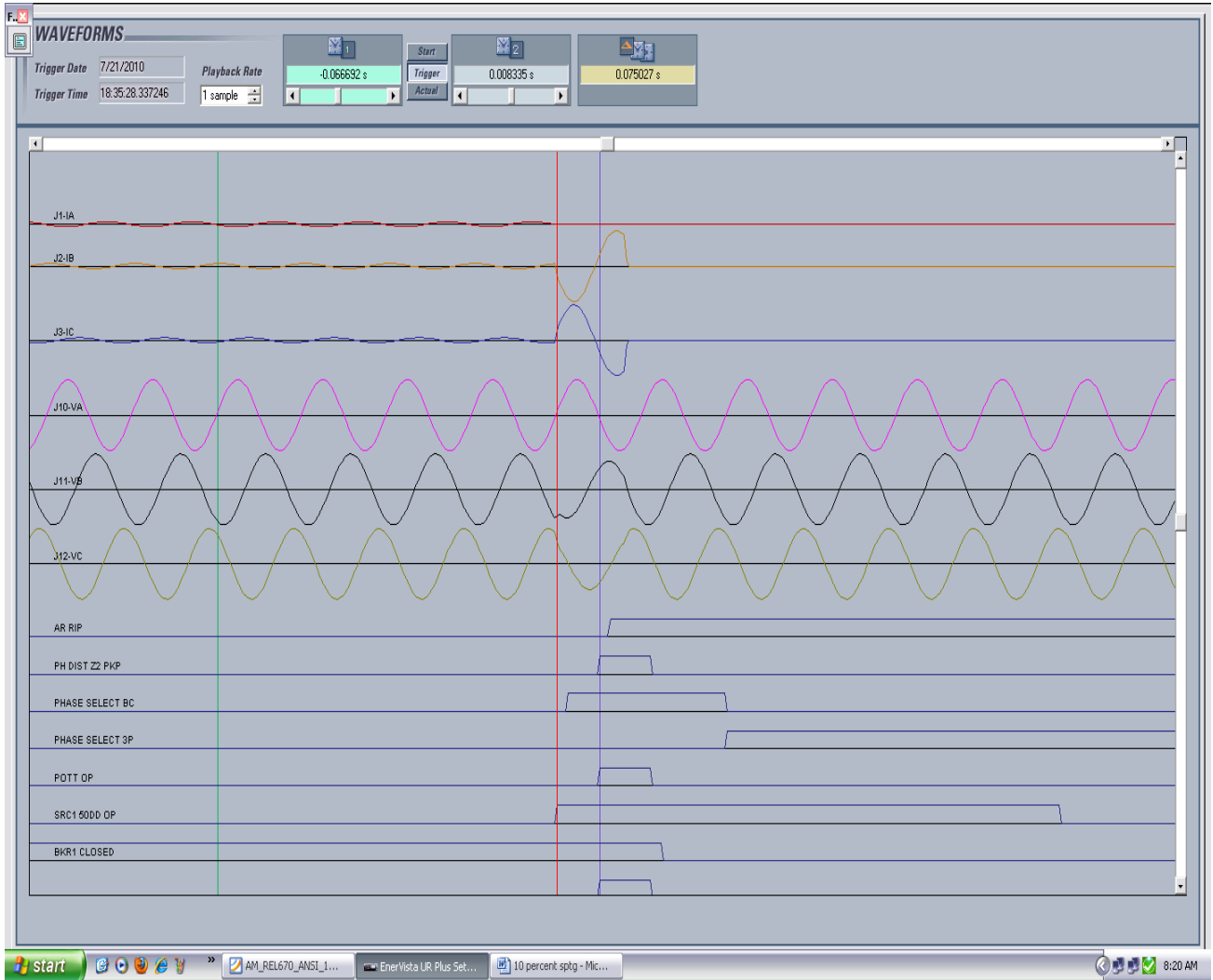

Figure 6.6: Relay 2 oscillography for line to line fault

Time taken by relay 2 to send the POTT Transmit signal using time stamps is

$$\begin{aligned}
 &= (\text{POTT TX trigger time} - \text{Disturbance using detector trigger time}) \\
 &= (0.007814 - 0.0) \text{ seconds} \\
 &= 7.814 \text{ millisecond}
 \end{aligned}$$

DOUBLE LINE TO GROUND FAULT

Relay 1 should pick up Phase Distance Zone 1, Zone 2 and send a POTT signal. It should operate for Zone 1. Relay 1 showed expected results.

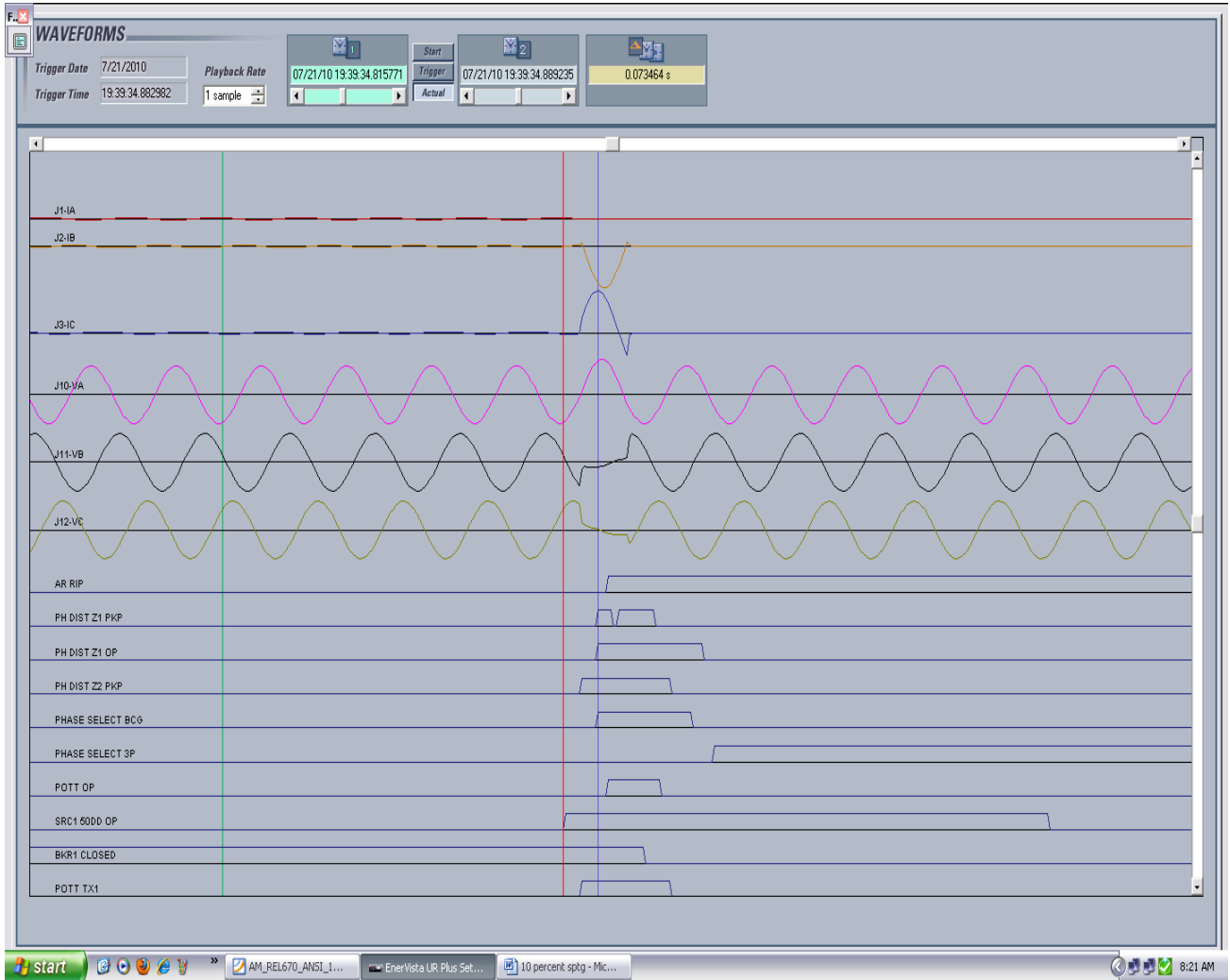

Figure 6.7: Relay 1 oscillography for double line to ground fault

The ground distance elements are less accurate during double line to ground faults. To prevent maloperation in such cases the relay uses fault type comparator which utilizes the phase angle between negative sequence current and zero sequence current to block the ground distance element from operating.

Time taken by relay 1 to send the POTT Transmit signal using time stamps is

$$= (\text{POTT TX trigger time} - \text{Disturbance using detector trigger time})$$

$$= (0.002608 - 0.0) \text{ seconds}$$

$$= 2.608 \text{ millisecond}$$

Relay 2 should pick up for Zone 2 and transmit a GOOSE POTT signal. It should trip for the Zone 2 or POTT. Relay 2 responded as expected, picking up for Zone 2 and operating at reception of remote input POTT trip signal.

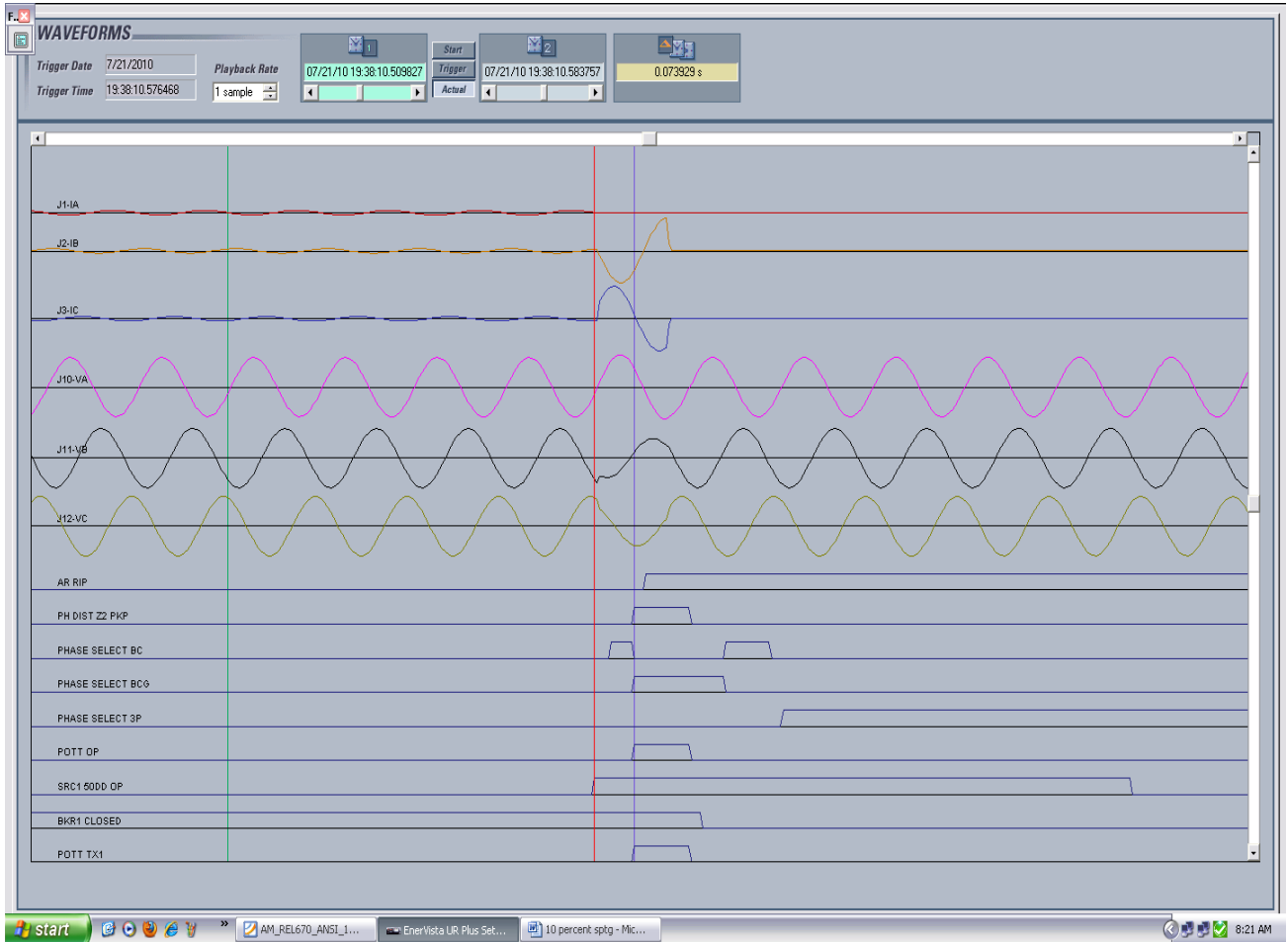

Figure 6.8: Relay 2 oscillography for double line to ground fault

Time taken by relay 2 to send the POTT Transmit signal using time stamps is

$$\begin{aligned}
 &= (\text{POTT TX trigger time} - \text{Disturbance using detector trigger time}) \\
 &= (0.006768 - 0.0) \text{ seconds} \\
 &= 6.768 \text{ millisecond}
 \end{aligned}$$

The relay response time (i.e. tripping time) is observed between relay 1 and relay 2 for 10% and 50% fault location from relay 1. The time is measured from the free version of Wireshark Network Protocol Analyzer version 1.2.6. Screen shots from wireshark are given below:

No. -	Time	Source	Destination	Protocol	Info
401	16:41:34.186838	Ge_02:02:99	Ge_02:02:99	GOOSE	
411	16:41:34.505321	Ge_02:02:9d	Ge_02:02:9d	GOOSE	
412	16:41:34.578747	Ge_02:02:a1	Ge_02:02:a1	GOOSE	
427	16:41:35.187758	Ge_02:02:99	Ge_02:02:99	GOOSE	
433	16:41:35.506268	Ge_02:02:9d	Ge_02:02:9d	GOOSE	
438	16:41:35.579726	Ge_02:02:a1	Ge_02:02:a1	GOOSE	
441	16:41:35.735769	Ge_02:02:99	Ge_02:02:99	GOOSE	
442	16:41:35.738715	Ge_02:02:9d	Ge_02:02:9d	GOOSE	
443	16:41:35.797056	Ge_02:02:9d	Ge_02:02:9d	GOOSE	
446	16:41:35.835739	Ge_02:02:99	Ge_02:02:99	GOOSE	
447	16:41:35.853522	Ge_02:02:99	Ge_02:02:99	GOOSE	
448	16:41:35.897978	Ge_02:02:9d	Ge_02:02:9d	GOOSE	
453	16:41:35.954410	Ge_02:02:99	Ge_02:02:99	GOOSE	
462	16:41:36.399015	Ge_02:02:9d	Ge_02:02:9d	GOOSE	

```

Frame 441 (141 bytes on wire, 141 bytes captured)
Ethernet II, Src: Ge_02:02:99 (00:a0:f4:02:02:99), Dst: Ge_02:02:99 (01:a0:f4:02:02:99)
GOOSE
  APPID: 0x0000 (0)
  Length: 127
  Reserved 1: 0x0000 (0)
  Reserved 2: 0x0000 (0)
  goosePdu
    gocbRef: IEDName_D90_1LDInst/LLN0$GO$gcb01
    timeAllowedtoLive: 400
    datset: IEDName_D90_1LDInst/LLN0$GOOSE1
    goID: D90-1
    t: 4BC77A3EE2D04E3F
    stNum: 35
    sqNum: 0
    test: False
    confRev: 4
    ndsCom: False
    numDatsetEntries: 2
    allData: 2 items
      Data: bit-string (4)
        Padding: 3
        bit-string: 0000
      Data: boolean (3)
        boolean: True
  
```

Figure 6.9: Relay 1 GOOSE message and tripping time (10% fault from station G)

No. .	Time	Source	Destination	Protocol	In
427	16:41:35.187758	Ge_02:02:99	Ge_02:02:99	GOOSE	
433	16:41:35.506268	Ge_02:02:9d	Ge_02:02:9d	GOOSE	
438	16:41:35.579726	Ge_02:02:a1	Ge_02:02:a1	GOOSE	
441	16:41:35.735769	Ge_02:02:99	Ge_02:02:99	GOOSE	
442	16:41:35.738715	Ge_02:02:9d	Ge_02:02:9d	GOOSE	
443	16:41:35.797056	Ge_02:02:9d	Ge_02:02:9d	GOOSE	
446	16:41:35.835739	Ge_02:02:99	Ge_02:02:99	GOOSE	
447	16:41:35.853522	Ge_02:02:99	Ge_02:02:99	GOOSE	
448	16:41:35.897978	Ge_02:02:9d	Ge_02:02:9d	GOOSE	
453	16:41:35.954410	Ge_02:02:99	Ge_02:02:99	GOOSE	
462	16:41:36.399015	Ge_02:02:9d	Ge_02:02:9d	GOOSE	
464	16:41:36.455478	Ge_02:02:99	Ge_02:02:99	GOOSE	
467	16:41:36.580599	Ge_02:02:a1	Ge_02:02:a1	GOOSE	
486	16:41:37.400026	Ge_02:02:9d	Ge_02:02:9d	GOOSE	

+ Frame 442 (129 bytes on wire, 129 bytes captured)
 + Ethernet II, Src: Ge_02:02:9d (00:a0:f4:02:02:9d), Dst: Ge_02:02:9d (01:a0:f4:02:02:9d)
 - GOOSE

```

APPID: 0x0000 (0)
Length: 115
Reserved 1: 0x0000 (0)
Reserved 2: 0x0000 (0)
- goosePdu
  gnchRef: IEDNameLDInst/LLN0$GO$gch01
  timeAllowedToLive: 400
  dataSet: IEDNameLDInst/LLN0$GOOSE1
  goID: D90-2
  t: 4BC//A04CD55E63F
  stNum: 47
  sqNum: 0
  test: False
  curRev: 13
  ndsCom: False
  numDataSetEntries: 7
- allData: 2 items
  - Data: bit-string (4)
    Padding: 3
    bit-string: 0000
  - Data: boolean (3)
    boolean: True
  
```

Figure 6.10: Relay 2 GOOSE message and tripping time (90% fault from station G)

No. -	Time	Source	Destination	Protocol	Info
392	16:55:40.607995	Ge_02:02:a1	Ge_02:02:a1	GOOSE	
409	16:55:41.319594	Ge_02:02:9d	Ge_02:02:9d	GOOSE	
413	16:55:41.469678	Ge_02:02:99	Ge_02:02:99	GOOSE	
416	16:55:41.610010	Ge_02:02:a1	Ge_02:02:a1	GOOSE	
432	16:55:42.320730	Ge_02:02:9d	Ge_02:02:9d	GOOSE	
435	16:55:42.470748	Ge_02:02:99	Ge_02:02:99	GOOSE	
440	16:55:42.611008	Ge_02:02:a1	Ge_02:02:a1	GOOSE	
460	16:55:43.321589	Ge_02:02:9d	Ge_02:02:9d	GOOSE	
464	16:55:43.471687	Ge_02:02:99	Ge_02:02:99	GOOSE	
467	16:55:43.612932	Ge_02:02:a1	Ge_02:02:a1	GOOSE	
475	16:55:43.872787	Ge_02:02:9d	Ge_02:02:9d	GOOSE	
476	16:55:43.872790	Ge_02:02:99	Ge_02:02:99	GOOSE	
477	16:55:43.935289	Ge_02:02:9d	Ge_02:02:9d	GOOSE	
478	16:55:43.973810	Ge_02:02:99	Ge_02:02:99	GOOSE	

⊞	Frame 475 (129 bytes on wire, 129 bytes captured)
⊞	Ethernet II, Src: Ge_02:02:9d (00:a0:f4:02:02:9d), Dst: Ge_02:02:9d (01:a0:f4:02:02:9d)
□	GOOSE
	APPTD: 0x0000 (0)
	Length: 115
	Reserved 1: 0x0000 (0)
	Reserved 2: 0x0000 (0)
□	goosePdu
	goCbrRef: IEDNameLDInst/LLN0\$GO\$gcb01
	timeAllowedtoLive: 100
	datSet: IEDNameLDInst/LLN0\$GOOSE1
	goID: D90-2
	t: 4BC77D54EE0DFD3F
	stNum: 49
	sqNum: 0
	test: False
	confRev: 13
	ndsCom: False
	numDatSetEntries: 2
□	allData: 2 items
	Data: bit-string (4)
	padding: 3
	bit string: 0000
	Data: boolean (3)
	boolean: True

Figure 6.11: Relay 1 GOOSE message and tripping time (50% fault from station G)

No. .	Time	Source	Destination	Protocol	Info
392	16:55:40.607995	Ge_02:02:a1	Ge_02:02:a1	GOOSE	
409	16:55:41.319594	Ge_02:02:9d	Ge_02:02:9d	GOOSE	
413	16:55:41.469678	Ge_02:02:99	Ge_02:02:99	GOOSE	
416	16:55:41.610010	Ge_02:02:a1	Ge_02:02:a1	GOOSE	
432	16:55:42.320730	Ge_02:02:9d	Ge_02:02:9d	GOOSE	
435	16:55:42.470748	Ge_02:02:99	Ge_02:02:99	GOOSE	
440	16:55:42.611008	Ge_02:02:a1	Ge_02:02:a1	GOOSE	
460	16:55:43.321589	Ge_02:02:9d	Ge_02:02:9d	GOOSE	
464	16:55:43.471687	Ge_02:02:99	Ge_02:02:99	GOOSE	
467	16:55:43.612932	Ge_02:02:a1	Ge_02:02:a1	GOOSE	
475	16:55:43.872787	Ge_02:02:9d	Ge_02:02:9d	GOOSE	
476	16:55:43.872790	Ge_02:02:99	Ge_02:02:99	GOOSE	
477	16:55:43.935289	Ge_02:02:9d	Ge_02:02:9d	GOOSE	
478	16:55:43.973810	Ge_02:02:99	Ge_02:02:99	GOOSE	

```

[-] Frame 476 (141 bytes on wire, 141 bytes captured)
[-] Ethernet II, Src: Ge_02:02:99 (00:a0:f4:02:02:99), Dst: Ge_02:02:99 (01:a0:f4:02:02:99)
[-] GOOSE
    APPID: 0x0000 (0)
    Length: 127
    Reserved 1: 0x0000 (0)
    Reserved 2: 0x0000 (0)
    [-] gooserd
        gnchrRef: TFDName_D90_1Inst/ILN0$G0$gch01
        timeAllowedToLive: 400
        dataSet: IEDName_D90_1LDInst/LLN0$GOOSE1
        goID: D90-1
        t: 4BC//D8F05004F3F
        stNum: 39
        sqNum: 0
        test: False
        curRev: 4
        ndsCom: false
        numDataSetEntries: 2
        [-] allData: 2 items
            [-] Data: bit-string (4)
                Padding: 3
                bit-string: 0000
            [-] Data: boolean (3)
                boolean: True
  
```

Figure 6.12: Relay 2 GOOSE message and tripping time (50% fault from station G)

When 10% fault is studied the time delay between two relays is 2.9 millisecond.

At 50% the time delay between the relays is found to be 3 microsecond.

CHAPTER 7

CONCLUSIONS

In this study, IEC 61850 GOOSE messaging is used to protect a 100 MVA, 161kV, 26 mile transmission line using Permissive Overreach Transfer Trip scheme. A fault was initiated at 2.6 mile from one end of the line. Fault currents and voltages for single phase to ground, three phase, line to line and double line to ground fault were calculated using MATLAB code. Zone 1 reach is set for 80% and zone2 reach is set for 125%. The relay were tested using OMICRON CMC 256-3 test set. Two GE D90^{Plus} Line distance relays were used for both ends of transmission line because of the unavailability of the ABB softwares at the time of study.

GOOSE messages were transmitted and received by both the relays through an Ethernet wire. The near end relay operated instantaneously and the far end relay operated upon the receipt of GOOSE message neglecting the Zone 2 time delay. The two GE D90^{Plus} relays operated within a subcycle time delay.

This study is a first step in realizing the IEC 61850 GOOSE messaging for transmission line protection under laboratory conditions. This thesis could be extended by communicating through GOOSE message between multivendors and creating the SCL files through third party software.

REFERENCES

- [1] E. Udreen, S. Kunsman, David J. Dolezilek, “Significant Substation Communications Standardization Developments,” Schweitzer Engineering Laboratories 2000, Pullman, Washington. [Online] Available: <http://www2.selinc.com/techpprs/6105.pdf>.
- [2] David J. Dolezilek, “IEC 61850: What you need to know about the functionality and implementation,” Proceedings for National Convention of AEIT 2004 Genoa Italy, Distributech 2005, WPDAC 2005, Praxis Profile, IEC 61850 Edition, July 2005.
- [3] K.Zimmerman “Microprocessor Based Distribution Relay Applications,” Technical Report, Schweitzer Engineering Laboratories Inc. [Online] Available: www2.selinc.com/techpprs/6013.pdf.
- [4] Ralph Mackiewicz “Technical Overview and Benefits of IEC 61850 Standard for Substation Automation,” *Proceedings of 2006 Power Systems Conference and Exposition*, IEEE, Oct. 29-Nov. 1, 2006, p. 623-630.
- [5] Petri Paananen, Specifying Configuration of Control Equipment According to IEC 61850, A Thesis Presented for MS degree, Royal Institute of Technology (KTH), Stockholm, Sweden, 2008.
- [6] Duncan J. Glover, Mulukutla S. Sarna and Thomas J. Overbye, Power System Analysis and Design, 4th edition, Publisher CL Engineering, May 2007
- [7] Schweitzer, Edmund O.,III and Feltis, Mark W., “Advances in Microprocessor-Based Relays,” Schweitzer Engineering Laboratories, Inc., Pullman, WA.

- [8] Nelson, John P., Sen, P.K., and Leoni, Andrew, "The New Science of Protective Relaying in the Petro-Chemical Industry," *IEEE Industry Application Magazine*, March/April 2000, pp. 34-58.
- [9] Eric Udren, David Dolezilek, "IEC 61850: Role Of Conformance Testing in Successful Integration," *Proceedings of the 8th Annual Western Power Delivery Automation Conference*, Spokane, WA, April 2006.
- [10] Schweitzer, Edmund O.,III, Scheer, Gary W., and Feltis, Mark W., "A Fresh Look at Distribution Protection," Schweitzer Engineering Laboratories, Inc., Pullman, WA., January 1992.
- [11] Mike Ingram, Randy Ehlers, "Towards Effective Substation Automation," *IEEE Power and Energy Magazine*, vol. 5, Issue 3, pub. 2007, p. 67-73.
- [12] Eric Udren "Electric Power Substation Monitoring, Protection, and Control in the New Century." Presentation delivered at Carnegie Mellon University on October 22, 2008.
www.eesg.ece.cmu.edu/Udren,%20Eric_CMU%20EESG%20Seminar%202_1022_08.pdf, last accessed on April 12, 2010.
- [13] Daqing Hou, Dave Dolezilek, "IEC 61850-What it can and cannot offer to traditional protection schemes," Schweitzer Engineering Laboratories, Inc., Pullman, WA.
- [14] Bogdan Kasztenny, James Whatley, Eric Udren, John Burger, Dale Finney, Mark Adamiak, "IEC-61850 a practical application primer for protection engineers," *Power Systems Conference: Advanced Metering, Protection, Control, Communication and Distributed Resources*, p. 18-50.

- [15] Mark Adamiak, Drew Baigent, Ralph Mackiewicz, "IEC 61850 Communication Networks and Systems in Substations: An Overview for Users," *GE Protection and Control Journal*, Spring 09.
- [16] Cagil R. Ozansoy, Aladin Zayegh, Akhtar Kalam, "The real time publisher/subscriber communication model for distributed substation systems," *IEEE Transactions on Power Delivery*, vol. 22, No. 3, July 2007, p. 1411-1423.
- [17] D90^{Plus} Line Distance Protection System Instruction Manual revision 1.6x, GE Digital Energy Multilin, Markham, Ontario, 2008.
- [18] Klaus-Peter Brand, "The Standard IEC 61850 as Prerequisite for Intelligent Applications in Substations," IEEE/PES General Meeting, USA 2004.
- [19] Jon Sykes, Mark Adamiak, Gustavo Brunello, "Implementation and Operational Experience of a Wide Area Protection Scheme on the Salt River Project System," *58th Annual Conference for Protective Relay Engineers*, 2005, Issue date: 5-7 April 2005, Page: 68.

APPENDICES

APPENDIX – 1

RELAY SETTINGS FILE

Exported On: Sun Jul 04 15:02:29 2010
EnerVista UR Plus Setup Version: 1.60
Device: D90-1
Product Order Code:: D90P-HE-AE03PSS-XHXABBCD01X
Product Version: 160
Selection: ENABLED Features
COMMUNICATIONS: NETWORK: ETHERNET
, Port 1 IP Address, 192.168.168.240
, Port 1 IP Subnet Mask, 255.255.255. 0
, Port 1 Gateway IP Address, 0. 0. 0. 0
, Port 1 Ethernet Mode, Auto
, Port 2 IP Address, 192.168.251.240
, Port 2 IP Subnet Mask, 255.255.255. 0
, Port 2 Gateway IP Address, 0. 0. 0. 0
, Port 2 Ethernet Mode, Auto
, Port 2 Redundancy, Single IP
, Port 3 IP Address, 192.168.253.253
, Port 3 IP Subnet Mask, 255.255.255. 0
, Port 3 Gateway IP Address, 0. 0. 0. 0
, Port 3 Ethernet Mode, Auto
, OSI Network Address (NSAP), 00
, ESH Configuration Timer, 120 s
, Configure IP Network Status, OK
, Active Port 1 IP Address, 0. 0. 0. 0
, Active Port 1 IP Subnet Mask, 0. 0. 0. 0
, Active Port 1 Gateway IP Address, 0. 0. 0. 0
, Active Port 2 IP Address, 0. 0. 0. 0
, Active Port 2 IP Subnet Mask, 0. 0. 0. 0
, Active Port 2 Gateway IP Address, 0. 0. 0. 0
, Active Port 3 IP Address, 0. 0. 0. 0
, Active Port 3 IP Subnet Mask, 0. 0. 0. 0
, Active Port 3 Gateway IP Address, 0. 0. 0. 0
IEC 61850: GSSE/GOOSE CONFIGURATION: TRANSMISSION: GENERAL
, Default GSSE/GOOSE Update Time, 1 s
TX CONFIGURABLE GOOSE

, Dataset 1 :GOOSEOut 1 Function, Enabled
, Dataset 1 :GOOSEOut 1 ID, D90-1
, Dataset 1 :GOOSEOut 1 Destination MAC, 00 00 00 00 00 00
, Dataset 1 :GOOSEOut 1 VLAN Priority, 7
, Dataset 1 :GOOSEOut 1 VLAN ID, 0
, Dataset 1 :GOOSEOut 1 ETYPE APPID, 0
, Dataset 1 :GOOSEOut 1 ConfRev, 17
, Dataset 1 :GOOSEOut 1 Dataset Item 1, GGIO1.ST.Ind1.q
, Dataset 1 :GOOSEOut 1 Dataset Item 2, GGIO1.ST.Ind1.stVal
RECEPTION: RX CONFIGURABLE GOOSE
, GOOSEIN 1: Dataset Item 1, GGIO3.ST.Ind1.q
, GOOSEIN 1: Dataset Item 2, GGIO3.ST.Ind1.stVal
, GOOSEIN 1: Dataset Item 3, None
INPUTS/OUTPUTS: REMOTE DEVICES
, Remote Device 1 ID, D90-2
, Remote Device 1 ETYPE APPID, 0
, Remote Device 1 DATASET, GOOSEIn 1
, Remote Device 2 ID, D90-3
, Remote Device 2 ETYPE APPID, 0
, Remote Device 2 DATASET, Fixed
, Remote Device 3 ID, D90-4
, Remote Device 3 ETYPE APPID, 0
, Remote Device 3 DATASET, Fixed
, Remote Device 4 ID, Remote Device 4
, Remote Device 4 ETYPE APPID, 0
, Remote Device 4 DATASET, Fixed
REMOTE INPUTS
, Remote Input 1 Name, Remo Ip 1
, Remote Input 1 Device, D90-2
, Remote Input 1 Item, Dataset Item 1
, Remote Input 1 Default State, Off
, Remote Input 1 Events, Enabled
, Remote Input 2 Name, Remo Ip 2
, Remote Input 2 Device, D90-2
, Remote Input 2 Item, Dataset Item 2
, Remote Input 2 Default State, Off
, Remote Input 2 Events, Enabled
GGIO1 STATUS CONFIGURATION
, Number of Status Points, 8
, GGIO1 Indication 1, POTT TX1
, GGIO1 Indication 2, Off

REAL TIME CLOCK
, IRIG-B Signal Type, None
, Real Time Clock Events, Enabled
, Time Zone Offset, -5.0 hr
, DST Function, Enabled
, DST Start Month, March
, DST Start Day, Sunday
, DST Start Day Instance, Second
, DST Start Hour, 2
, DST Stop Month, November
, DST Stop Day, Sunday
, DST Stop Day Instance, First
, DST Stop Hour, 2
SERIAL PORTS
, Baud Rate, 19200
, Parity, None
, Minimum Response Time, 0 ms
, Connection, Local
PROTECTION: POWER SYSTEM: INSTALLATION
, Relay Settings, Programmed
, Relay Name, D90-1
, User Configuration Name, EGEE591
AC INPUTS - CURRENT
, CT J1: Phase CT Ratio, 300
, CT J1: Phase CT Secondary, 5 A
, CT J4: Phase CT Ratio, 300
, CT J7: Ground CT Ratio, 300
, CT J7: Ground CT Secondary, 5 A
, CT J1: Current Cutoff Level, 0.020 pu
AC INPUTS - VOLTAGE
, VT J8: Auxiliary VT Connection, Vag
, VT J8: Auxiliary VT Secondary, 66.4 V
, VT J8: Auxiliary VT Ratio, 1400.00 :1
, VT J9: Auxiliary VT Connection, Vag
, VT J9: Auxiliary VT Secondary, 66.4 V
, VT J9: Auxiliary VT Ratio, 1400.00 :1
, VT J10: Phase VT Connection, Wye
, VT J10: Phase VT Secondary, 66.4 V
, VT J10: Phase VT Ratio, 1400.00 :1
, VT J8: Voltage Cutoff Level, 1.0 V

FREQUENCY
, Nominal Frequency, 60 Hz
, Phase Rotation, ABC
, Frequency And Phase Reference, SRC 1
, Frequency Tracking Function, Enabled
SIGNAL SOURCES
, SOURCE 1: Name, LINE
, SOURCE 1: Phase CT, J1
, SOURCE 1: Ground CT, None
, SOURCE 1: Phase VT, J10
, SOURCE 1: Auxiliary VT, None
DISTANCE [GROUP 1]
, Source, SRC 1
, Memory Duration, 10 cycles
, Force Self-Polarization, Off
, Force Memory Polarization, Off
, CVT Filter Function, Disabled
, CVT Filter T1, 1.00 ms
, CVT Filter T2, 1.00 ms
, CVT Filter Tx, 1.00 ms
PHASE DISTANCE [GROUP 1]
, CONFIGURATION: Zone 1 : Function, Enabled
, CONFIGURATION: Zone 1 : Direction, Forward
, CONFIGURATION: Zone 1 : Shape, Mho
, CONFIGURATION: Zone 1 : Transformer Voltage Connection, None
, CONFIGURATION: Zone 1 : Transformer Current Connection, None
, CONFIGURATION: Zone 1 : Reach, 3.66 ohms
, CONFIGURATION: Zone 1 : RCA, 72 deg
, CONFIGURATION: Zone 1 : Reverse Reach, 2.00 ohms
, CONFIGURATION: Zone 1 : Reverse Reach RCA, 90 deg
, CONFIGURATION: Zone 1 : Comparator Limit, 90 deg
, CONFIGURATION: Zone 1 : Directional RCA, 72 deg
, CONFIGURATION: Zone 1 : Directional Comparator Limit, 85 deg
, CONFIGURATION: Zone 1 : Quadrilateral Right Blinder, 0.90 ohms
, CONFIGURATION: Zone 1 : Quadrilateral Right Blinder RCA, 85 deg
, CONFIGURATION: Zone 1 : Quadrilateral Left Blinder, 0.85 ohms
, CONFIGURATION: Zone 1 : Quadrilateral Left Blinder RCA, 85 deg
, CONFIGURATION: Zone 1 : Supervision, 0.200 pu
, CONFIGURATION: Zone 1 : Volt Level, 0.000 pu
, CONFIGURATION: Zone 1 : Delay, 0.000 s

, CONFIGURATION: Zone 1 : Block, Off
, CONFIGURATION: Zone 1 : Events, Enabled
, CONFIGURATION: Zone 2 : Function, Enabled
, CONFIGURATION: Zone 2 : Direction, Forward
, CONFIGURATION: Zone 2 : Shape, Mho
, CONFIGURATION: Zone 2 : Transformer Voltage Connection, None
, CONFIGURATION: Zone 2 : Transformer Current Connection, None
, CONFIGURATION: Zone 2 : Reach, 5.72 ohms
, CONFIGURATION: Zone 2 : RCA, 72 deg
, CONFIGURATION: Zone 2 : Reverse Reach, 2.00 ohms
, CONFIGURATION: Zone 2 : Reverse Reach RCA, 90 deg
, CONFIGURATION: Zone 2 : Comparator Limit, 90 deg
, CONFIGURATION: Zone 2 : Directional RCA, 72 deg
, CONFIGURATION: Zone 2 : Directional Comparator Limit, 85 deg
, CONFIGURATION: Zone 2 : Quadrilateral Right Blinder, 0.85 ohms
, CONFIGURATION: Zone 2 : Quadrilateral Right Blinder RCA, 85 deg
, CONFIGURATION: Zone 2 : Quadrilateral Left Blinder, 0.85 ohms
, CONFIGURATION: Zone 2 : Quadrilateral Left Blinder RCA, 85 deg
, CONFIGURATION: Zone 2 : Supervision, 0.200 pu
, CONFIGURATION: Zone 2 : Volt Level, 0.000 pu
, CONFIGURATION: Zone 2 : Delay, 0.300 s
, CONFIGURATION: Zone 2 : Block, Off
, CONFIGURATION: Zone 2 : Events, Enabled
GROUND DISTANCE [GROUP 1]
, CONFIGURATION: Zone 1 : Function, Enabled
, CONFIGURATION: Zone 1 : Direction, Forward
, CONFIGURATION: Zone 1 : Shape, Mho
, CONFIGURATION: Zone 1 : Z0/Z1 Magnitude, 3.00
, CONFIGURATION: Zone 1 : Z0/Z1 Angle, 0 deg
, CONFIGURATION: Zone 1 : Z0M/Z1 Magnitude, 0.85
, CONFIGURATION: Zone 1 : Z0M/Z1 Angle, 0 deg
, CONFIGURATION: Zone 1 : Reach, 3.66 ohms
, CONFIGURATION: Zone 1 : RCA, 72 deg
, CONFIGURATION: Zone 1 : Reverse Reach, 2.00 ohms
, CONFIGURATION: Zone 1 : Reverse Reach RCA, 85 deg
, CONFIGURATION: Zone 1 : Polarizing Current, Zero-seq
, CONFIGURATION: Zone 1 : Non-Homogeneous Angle, 0.0 deg
, CONFIGURATION: Zone 1 : Comparator Limit, 90 deg
, CONFIGURATION: Zone 1 : Directional RCA, 85 deg
, CONFIGURATION: Zone 1 : Directional Comparator Limit, 85 deg
, CONFIGURATION: Zone 1 : Quadrilateral Right Blinder, 0.90 ohms

, CONFIGURATION: Zone 1 : Quadrilateral Right Blinder RCA, 85 deg
, CONFIGURATION: Zone 1 : Quadrilateral Left Blinder, 0.85 ohms
, CONFIGURATION: Zone 1 : Quadrilateral Left Blinder RCA, 85 deg
, CONFIGURATION: Zone 1 : Supervision, 0.200 pu
, CONFIGURATION: Zone 1 : Volt Level, 0.000 pu
, CONFIGURATION: Zone 1 : Delay, 0.000 s
, CONFIGURATION: Zone 1 : Block, Off
, CONFIGURATION: Zone 1 : Events, Enabled
, CONFIGURATION: Zone 2 : Function, Enabled
, CONFIGURATION: Zone 2 : Direction, Forward
, CONFIGURATION: Zone 2 : Shape, Mho
, CONFIGURATION: Zone 2 : Z0/Z1 Magnitude, 3.00
, CONFIGURATION: Zone 2 : Z0/Z1 Angle, 0 deg
, CONFIGURATION: Zone 2 : Z0M/Z1 Magnitude, 0.85
, CONFIGURATION: Zone 2 : Z0M/Z1 Angle, 0 deg
, CONFIGURATION: Zone 2 : Reach, 5.72 ohms
, CONFIGURATION: Zone 2 : RCA, 72 deg
, CONFIGURATION: Zone 2 : Reverse Reach, 2.00 ohms
, CONFIGURATION: Zone 2 : Reverse Reach RCA, 85 deg
, CONFIGURATION: Zone 2 : Polarizing Current, Zero-seq
, CONFIGURATION: Zone 2 : Non-Homogeneous Angle, 0.0 deg
, CONFIGURATION: Zone 2 : Comparator Limit, 90 deg
, CONFIGURATION: Zone 2 : Directional RCA, 85 deg
, CONFIGURATION: Zone 2 : Directional Comparator Limit, 85 deg
, CONFIGURATION: Zone 2 : Quadrilateral Right Blinder, 0.90 ohms
, CONFIGURATION: Zone 2 : Quadrilateral Right Blinder RCA, 85 deg
, CONFIGURATION: Zone 2 : Quadrilateral Left Blinder, 0.85 ohms
, CONFIGURATION: Zone 2 : Quadrilateral Left Blinder RCA, 85 deg
, CONFIGURATION: Zone 2 : Supervision, 0.200 pu
, CONFIGURATION: Zone 2 : Volt Level, 0.000 pu
, CONFIGURATION: Zone 2 : Delay, 0.300 s
, CONFIGURATION: Zone 2 : Block, Off
, CONFIGURATION: Zone 2 : Events, Enabled
POTT SCHEME
, Function, Enabled
, Block, Off
, Permissive Echo, Disabled
, Echo Condition, Off
, RX Pickup Delay, 0.000 s
, Transient Block Pickup Delay, 0.020 s

, Trans Block Reset Delay, 0.090 s
, Echo Duration, 0.100 s
, Echo Lockout, 0.250 s
, Line End Open Pickup Delay, 0.050 s
, Seal-In Delay, 0.000 s
, Ground Directional OC Forward, Off
, Communication Bits, 1
, Rx1, Remo Ip 2 On (RI2)
, Rx2, Off
, Rx3, Off
, Rx4, Off
, Event, Enabled
AUTORECLOSE
, Function, Enabled
, Mode, 3 Pole - B
, HMI Control, Enabled
, Tagging, Disabled
, Local Control, On
, Remote Control, Off
, Select Time, 5.0 s
, Maximum Number of Shots, 4
, Block Breaker 1, Off
, Breaker 1 Close Time, 0.10 s
, Breaker Man Close, Off
, Block Time Upon Manual Close, 2.00 s
, 1-Pole Initiate, Off
, 3-Pole Initiate, Trip On (VO2)
, 3-Pole TD Initiate, Off
, Multi-Phase Fault, Off
, Breaker 1-Pole Open, Off
, Breaker 3-Pole Open, BKR1 52a Off(E5)
, 3-Pole Dead Time 1, 0.50 s
, 3-Pole Dead Time 2, 1.20 s
, 3-Pole Dead Time 3, 2.00 s
, 3-Pole Dead Time 4, 4.00 s
, Extend Dead Time 1, Off
, Dead Time 1 Extension, 0.50 s
, Reset From Lockout, PUSHBUTTON 2 ON
, Reset Time, 60.00 s
, Breaker Closed, BKR1 52a On(E5)

, Block, Off
, Pause, Off
, Incomplete Sequence Time, 5.00 s
, Block Breaker 2, Off
, Breaker 2 Close Time, 0.10 s
, Transfer 1 to 2, No
, Transfer 2 to 1, No
, Breaker 1 Fail Option, Continue
, Breaker 2 Fail Option, Continue
, 1-Pole Dead Time, 1.00 s
, Breaker Sequence, 1 - 2
, Transfer Time, 4.00 s
, Bus Fault Init, Off
, Event, Enabled
BREAKERS
, [Breaker 1] : Function, Enabled
, [Breaker 1] : Long Name, Breaker 1
, [Breaker 1] : Short Name, BKR1
, [Breaker 1] : Substitution, Disabled
, [Breaker 1] : Combined Protection and Control, Disabled
, [Breaker 1] : External Trip A, Off
, [Breaker 1] : External Trip B, Off
, [Breaker 1] : External Trip C, Off
, [Breaker 1] : External Trip, Off
, [Breaker 1] : External Open Command, Off
, [Breaker 1] : Block Open Command, Off
, [Breaker 1] : External Close Command, Off
, [Breaker 1] : Autoreclose Close Supervision, Off
, [Breaker 1] : Block Close Command, Off
, [Breaker 1] : Breaker Local Input, Off
, [Breaker 1] : Indication Mode, 3-Pole
, [Breaker 1] : Phase A/3P Closed Status, BKR1 52a On(E5)
, [Breaker 1] : Phase A/3P Opened Status, BKR1 52a Off(E5)
, [Breaker 1] : Phase B Closed Status, Off
, [Breaker 1] : Phase B Opened Status, Off
, [Breaker 1] : Phase C Closed Status, Off
, [Breaker 1] : Phase C Opened Status, On
, [Breaker 1] : Operate Time, 0.070 s
, [Breaker 1] : Discrepancy Time, 0.070 s
, [Breaker 1] : Reset Counter, Off

, [Breaker 1] : Events, Enabled
PROTECTION INPUTS/OUTPUTS: VIRTUAL INPUTS
, [PROT VI 1] : Function, Enabled
, [PROT VI 1] : ID, Virt Ip 1
, [PROT VI 1] : Type, Latched
, [PROT VI 1] : Events, Enabled
CONTACT INPUTS: CONTACT INPUTS
, [E5] : ID, BKR1 52a
, [E5] : Debounce Time, 2.00 ms
, [E5] : Nominal Voltage, 125 V
, [E5] : Events, Enabled
, [E6] : ID, BKR2 52a
, [E6] : Debounce Time, 2.00 ms
, [E6] : Nominal Voltage, 125 V
, [E6] : Events, Enabled
, [E7] : ID, Cont Ip 3
, [E7] : Debounce Time, 2.00 ms
, [E7] : Nominal Voltage, 125 V
, [E7] : Events, Enabled
CONTACT OUTPUTS
, [E1] : ID, BKR1 TR COIL
, [E1] : Operate, Trip On (VO2)
, [E1] : Seal-In, Off
, [E1] : Voltage Threshold, 20
, [E1] : Events, Enabled
, [E2] : ID, BKR1 CL COIL
, [E2] : Operate, Closed On (VO3)
, [E2] : Seal-In, Off
, [E2] : Voltage Threshold, 20
, [E2] : Events, Enabled
, [E3] : ID, BKR2 TR COIL
, [E3] : Operate, BKR2 TRIP CMD 3-POLE
, [E3] : Seal-In, BKR2 TR COIL IOn (E3)
, [E3] : Voltage Threshold, 20
, [E3] : Events, Enabled
, [E4] : ID, BKR2 CL COIL
, [E4] : Operate, BKR2 CLOSE CMD
, [E4] : Seal-In, BKR2 CL COIL IOn (E4)
, [E4] : Voltage Threshold, 20
, [E4] : Events, Enabled

PROTECTION FLEXLOGIC: FLEXLOGIC EQUATION EDITOR
, FlexLogic Entry 1 , ANY PB ON
, FlexLogic Entry 2 , = Virt Op 1 (VO1)
, FlexLogic Entry 3 , PH DIST Z1 OP
, FlexLogic Entry 4 , PH DIST Z2 OP
, FlexLogic Entry 5 , GND DIST Z1 OP
, FlexLogic Entry 6 , GND DIST Z2 OP
, FlexLogic Entry 7 , POTT OP
, FlexLogic Entry 8 , OR(5)
, FlexLogic Entry 9 , = RI (VO4)
, FlexLogic Entry 10 , BKR1 CTRL CLOSE CMD
, FlexLogic Entry 11 , AR CLOSE BKR1
, FlexLogic Entry 12 , OR(2)
, FlexLogic Entry 13 , = Closed (VO3)
, FlexLogic Entry 14 , BKR1 CTRL OPEN CMD
, FlexLogic Entry 15 , RI On (VO4)
, FlexLogic Entry 16 , OR(2)
, FlexLogic Entry 17 , = Trip (VO2)
, FlexLogic Entry 18 , END
AUTOMATION: BREAKER: BREAKER CONTROL
, [Breaker 1] : Function, Enabled
, [Breaker 1] : HMI Control, Enabled
, [Breaker 1] : Local Control, On
, [Breaker 1] : Remote Control, Off
, [Breaker 1] : Select Time, 10.0 s
, [Breaker 1] : Automatic Close, Off
, [Breaker 1] : Automatic Open, Off
, [Breaker 1] : Execute Time, 10.0 s
, [Breaker 1] : Control Bypass, Disabled
, [Breaker 1] : Auto Bypass, Off
, [Breaker 1] : Bypass Time, 10.0 s
, [Breaker 1] : Events, Enabled
, [Breaker 2] : Function, Enabled
, [Breaker 2] : HMI Control, Enabled
, [Breaker 2] : Local Control, L/R-L On
, [Breaker 2] : Remote Control, L/R-R On
, [Breaker 2] : Select Time, 10.0 s
, [Breaker 2] : Automatic Close, Off
, [Breaker 2] : Automatic Open, Off

, [Breaker 2] : Execute Time, 10.0 s
, [Breaker 2] : Control Bypass, Disabled
, [Breaker 2] : Auto Bypass, Off
, [Breaker 2] : Bypass Time, 10.0 s
, [Breaker 2] : Events, Enabled
AUTOMATION INPUTS/OUTPUTS
CONTACT INPUTS
, [F5] : ID, DSC1 89a
, [F5] : Debounce Time, 2.00 ms
, [F5] : Nominal Voltage, 125 V
, [F5] : Events, Enabled
, [F6] : ID, DSC2 89a
, [F6] : Debounce Time, 2.00 ms
, [F6] : Nominal Voltage, 125 V
, [F6] : Events, Enabled
, [F7] : ID, Cont Ip 11
, [F7] : Debounce Time, 2.00 ms
, [F7] : Nominal Voltage, 125 V
, [F7] : Events, Enabled
, [F8] : ID, Cont Ip 12
, [F8] : Debounce Time, 2.00 ms
, [F8] : Nominal Voltage, 125 V
, [F8] : Events, Enabled
, [F9] : ID, Cont Ip 13
, [F9] : Debounce Time, 2.00 ms
, [F9] : Nominal Voltage, 125 V
, [F9] : Events, Enabled
, [F10] : ID, Cont Ip 14
, [F10] : Debounce Time, 2.00 ms
, [F10] : Nominal Voltage, 125 V
, [F10] : Events, Enabled
CONTACT OUTPUTS
, [F1] : ID, DSC1 TR COIL
, [F1] : Operate, DSC1 OPEN CMD
, [F1] : Seal-In, Off
, [F1] : Voltage Threshold, 20
, [F1] : Events, Enabled
, [F2] : ID, DSC1 CL COIL
, [F2] : Operate, DSC1 CLOSE CMD

, [F2] : Seal-In, Off
, [F2] : Voltage Threshold, 20
, [F2] : Events, Enabled
, [F3] : ID, DSC2 TR COIL
, [F3] : Operate, DSC2 OPEN CMD
, [F3] : Seal-In, Off
, [F3] : Voltage Threshold, 20
, [F3] : Events, Enabled
, [F4] : ID, DSC2 CL COIL
, [F4] : Operate, DSC2 CLOSE CMD
, [F4] : Seal-In, Off
, [F4] : Voltage Threshold, 20
, [F4] : Events, Enabled
DFR: FAULT REPORT
, Source, SRC 1
, Trigger, TRIP 3-POLE
, Positive-Sequence (Z1) Magnitude, 4.57 ohms
, Positive-Sequence (Z1) Angle, 72 deg
, Zero-Sequence (Z0) Magnitude, 13.72 ohms
, Zero-Sequence (Z0) Angle, 72 deg
, Line Length Units, miles
, Line Length, 26.0
, Fault Report VT Substitution, None
, Fault Report System Z0 Mag, 0.01
, Fault Report System Z0 Angle, 25
TRANSIENT RECORD
, Function, Enabled
, Number Of Records, 48
, Trigger Mode, Automatic Overwrite
, Trigger Position, 50 %
, Maximum Retriggers, 2
, Sample Rate, 32 samples/cycle
, Block Trigger, Off
OSCILLOGRAPHY ANALOG CHANNELS
, [Analog Channel 1] :Available Signals, LINE Vag Mag
, [Analog Channel 1] :High Trigger, OFF
, [Analog Channel 1] :High Pickup, 1000.0
, [Analog Channel 1] :Low Trigger, OFF
, [Analog Channel 1] :Low Pickup, 1000.0

, [Analog Channel 1] :Block Trigger, Off
, [Analog Channel 2] :Available Signals, LINE Vag Angle
, [Analog Channel 2] :High Trigger, OFF
, [Analog Channel 2] :High Pickup, 1000.0
, [Analog Channel 2] :Low Trigger, OFF
, [Analog Channel 2] :Low Pickup, 1000.0
, [Analog Channel 2] :Block Trigger, Off
, [Analog Channel 3] :Available Signals, LINE Vbg Mag
, [Analog Channel 3] :High Trigger, OFF
, [Analog Channel 3] :High Pickup, 1000.0
, [Analog Channel 3] :Low Trigger, OFF
, [Analog Channel 3] :Low Pickup, 1000.0
, [Analog Channel 3] :Block Trigger, Off
, [Analog Channel 4] :Available Signals, LINE Vbg Angle
, [Analog Channel 4] :High Trigger, OFF
, [Analog Channel 4] :High Pickup, 1000.0
, [Analog Channel 4] :Low Trigger, OFF
, [Analog Channel 4] :Low Pickup, 1000.0
, [Analog Channel 4] :Block Trigger, Off
, [Analog Channel 5] :Available Signals, LINE Vcg Mag
, [Analog Channel 5] :High Trigger, OFF
, [Analog Channel 5] :High Pickup, 1000.0
, [Analog Channel 5] :Low Trigger, OFF
, [Analog Channel 5] :Low Pickup, 1000.0
, [Analog Channel 5] :Block Trigger, Off
, [Analog Channel 6] :Available Signals, LINE Vcg Angle
, [Analog Channel 6] :High Trigger, OFF
, [Analog Channel 6] :High Pickup, 1000.0
, [Analog Channel 6] :Low Trigger, OFF
, [Analog Channel 6] :Low Pickup, 1000.0
, [Analog Channel 6] :Block Trigger, Off
, [Analog Channel 7] :Available Signals, LINE Ia Mag
, [Analog Channel 7] :High Trigger, OFF
, [Analog Channel 7] :High Pickup, 1000.0
, [Analog Channel 7] :Low Trigger, OFF
, [Analog Channel 7] :Low Pickup, 1000.0
, [Analog Channel 7] :Block Trigger, Off
, [Analog Channel 8] :Available Signals, LINE Ia Angle
, [Analog Channel 8] :High Trigger, OFF
, [Analog Channel 8] :High Pickup, 1000.0
, [Analog Channel 8] :Low Trigger, OFF

, [Analog Channel 8] :Low Pickup, 1000.0
, [Analog Channel 8] :Block Trigger, Off
, [Analog Channel 9] :Available Signals, LINE Ib Mag
, [Analog Channel 9] :High Trigger, OFF
, [Analog Channel 9] :High Pickup, 1000.0
, [Analog Channel 9] :Low Trigger, OFF
, [Analog Channel 9] :Low Pickup, 1000.0
, [Analog Channel 9] :Block Trigger, Off
, [Analog Channel 10] :Available Signals, LINE Ib Angle
, [Analog Channel 10] :High Trigger, OFF
, [Analog Channel 10] :High Pickup, 1000.0
, [Analog Channel 10] :Low Trigger, OFF
, [Analog Channel 10] :Low Pickup, 1000.0
, [Analog Channel 10] :Block Trigger, Off
, [Analog Channel 11] :Available Signals, LINE Ic Mag
, [Analog Channel 11] :High Trigger, OFF
, [Analog Channel 11] :High Pickup, 1000.0
, [Analog Channel 11] :Low Trigger, OFF
, [Analog Channel 11] :Low Pickup, 1000.0
, [Analog Channel 11] :Block Trigger, Off
, [Analog Channel 12] :Available Signals, LINE Ic Angle
, [Analog Channel 12] :High Trigger, OFF
, [Analog Channel 12] :High Pickup, 1000.0
, [Analog Channel 12] :Low Trigger, OFF
, [Analog Channel 12] :Low Pickup, 1000.0
, [Analog Channel 12] :Block Trigger, Off
, [Analog Channel 13] :High Trigger, OFF
, [Analog Channel 13] :High Pickup, 1000.0
, [Analog Channel 13] :Low Trigger, OFF
, [Analog Channel 13] :Low Pickup, 1000.0
, [Analog Channel 13] :Block Trigger, Off
, [Analog Channel 14] :High Trigger, OFF
, [Analog Channel 14] :High Pickup, 1000.0
, [Analog Channel 14] :Low Trigger, OFF
, [Analog Channel 14] :Low Pickup, 1000.0
, [Analog Channel 14] :Block Trigger, Off
, [Analog Channel 15] :High Trigger, OFF
, [Analog Channel 15] :High Pickup, 1000.0
, [Analog Channel 15] :Low Trigger, OFF
, [Analog Channel 15] :Low Pickup, 1000.0
, [Analog Channel 15] :Block Trigger, Off

, [Analog Channel 16] :High Trigger, OFF
, [Analog Channel 16] :High Pickup, 1000.0
, [Analog Channel 16] :Low Trigger, OFF
, [Analog Channel 16] :Low Pickup, 1000.0
, [Analog Channel 16] :Block Trigger, Off
OSCILLOGRAPHY DIGITAL CHANNELS
, [Digital Channel 1] :Signals, AR ENABLED
, [Digital Channel 1] :Trigger, OFF
, [Digital Channel 2] :Signals, AR RIP
, [Digital Channel 2] :Trigger, OFF
, [Digital Channel 3] :Signals, AR CLOSE BKR1
, [Digital Channel 3] :Trigger, OFF
, [Digital Channel 4] :Signals, AR CLOSE BKR2
, [Digital Channel 4] :Trigger, OFF
, [Digital Channel 5] :Signals, AUX OV1 OP
, [Digital Channel 5] :Trigger, OFF
, [Digital Channel 6] :Signals, AUX UV1 OP
, [Digital Channel 6] :Trigger, OFF
, [Digital Channel 7] :Signals, DIR BLOCK OP
, [Digital Channel 7] :Trigger, OFF
, [Digital Channel 8] :Signals, BKR FAIL 1 RETRIP
, [Digital Channel 8] :Trigger, OFF
, [Digital Channel 9] :Signals, BKR FAIL 1 TRIP OP
, [Digital Channel 9] :Trigger, TRIGGER ONLY
, [Digital Channel 10] :Signals, BKR FAIL 2 RETRIP
, [Digital Channel 10] :Trigger, OFF
, [Digital Channel 11] :Signals, BKR FAIL 2 TRIP OP
, [Digital Channel 11] :Trigger, TRIGGER ONLY
, [Digital Channel 12] :Signals, BKR1 OPEN CMD
, [Digital Channel 12] :Trigger, OFF
, [Digital Channel 13] :Signals, BKR1 CLOSE CMD
, [Digital Channel 13] :Trigger, OFF
, [Digital Channel 14] :Signals, BKR2 OPEN CMD
, [Digital Channel 14] :Trigger, OFF
, [Digital Channel 15] :Signals, BKR2 CLOSE CMD
, [Digital Channel 15] :Trigger, OFF
, [Digital Channel 16] :Signals, GND DIST Z1 PKP
, [Digital Channel 16] :Trigger, TRIGGER ONLY
, [Digital Channel 17] :Signals, GND DIST Z1 OP
, [Digital Channel 17] :Trigger, TRIGGER ONLY

, [Digital Channel 18] :Signals, GND DIST Z2 PKP
, [Digital Channel 18] :Trigger, TRIGGER ONLY
, [Digital Channel 19] :Signals, GND DIST Z2 OP
, [Digital Channel 19] :Trigger, TRIGGER ONLY
, [Digital Channel 20] :Signals, GND DIST Z3 PKP
, [Digital Channel 20] :Trigger, TRIGGER ONLY
, [Digital Channel 21] :Signals, GND DIST Z3 OP
, [Digital Channel 21] :Trigger, TRIGGER ONLY
, [Digital Channel 22] :Signals, GND DIST Z4 PKP
, [Digital Channel 22] :Trigger, TRIGGER ONLY
, [Digital Channel 23] :Signals, GND DIST Z4 OP
, [Digital Channel 23] :Trigger, TRIGGER ONLY
, [Digital Channel 24] :Signals, GND DIST Z5 PKP
, [Digital Channel 24] :Trigger, TRIGGER ONLY
, [Digital Channel 25] :Signals, GND DIST Z5 OP
, [Digital Channel 25] :Trigger, TRIGGER ONLY
, [Digital Channel 26] :Signals, GROUND IOC1 OP
, [Digital Channel 26] :Trigger, TRIGGER ONLY
, [Digital Channel 27] :Signals, GROUND TOC1 OP
, [Digital Channel 27] :Trigger, TRIGGER ONLY
, [Digital Channel 28] :Signals, HYBRID POTT OP
, [Digital Channel 28] :Trigger, TRIGGER ONLY
, [Digital Channel 29] :Signals, LINE PICKUP OP
, [Digital Channel 29] :Trigger, TRIGGER ONLY
, [Digital Channel 30] :Signals, LOAD ENCRO OP
, [Digital Channel 30] :Trigger, TRIGGER ONLY
, [Digital Channel 31] :Signals, NEG SEQ DIR OC1 FWD
, [Digital Channel 31] :Trigger, OFF
, [Digital Channel 32] :Signals, NEG SEQ DIR OC1 REV
, [Digital Channel 32] :Trigger, OFF
, [Digital Channel 33] :Signals, NEG SEQ IOC1 OP
, [Digital Channel 33] :Trigger, OFF
, [Digital Channel 34] :Signals, NEG SEQ TOC1 OP
, [Digital Channel 34] :Trigger, OFF
, [Digital Channel 35] :Signals, NEUTRAL IOC1 OP
, [Digital Channel 35] :Trigger, TRIGGER ONLY
, [Digital Channel 36] :Signals, NEUTRAL TOC1 OP
, [Digital Channel 36] :Trigger, TRIGGER ONLY
, [Digital Channel 37] :Signals, NEG SEQ OV1 OP
, [Digital Channel 37] :Trigger, OFF
, [Digital Channel 38] :Signals, NEUTRAL OV1 OP

, [Digital Channel 38] :Trigger, OFF
, [Digital Channel 39] :Signals, NTRL DIR OC1 FWD
, [Digital Channel 39] :Trigger, OFF
, [Digital Channel 40] :Signals, NTRL DIR OC2 FWD
, [Digital Channel 40] :Trigger, OFF
, [Digital Channel 41] :Signals, PH DIR1 BLK A
, [Digital Channel 41] :Trigger, OFF
, [Digital Channel 42] :Signals, PH DIR1 BLK B
, [Digital Channel 42] :Trigger, OFF
, [Digital Channel 43] :Signals, PH DIR1 BLK C
, [Digital Channel 43] :Trigger, OFF
, [Digital Channel 44] :Signals, PH DIST Z1 PKP
, [Digital Channel 44] :Trigger, TRIGGER ONLY
, [Digital Channel 45] :Signals, PH DIST Z1 OP
, [Digital Channel 45] :Trigger, TRIGGER ONLY
, [Digital Channel 46] :Signals, PH DIST Z2 PKP
, [Digital Channel 46] :Trigger, TRIGGER ONLY
, [Digital Channel 47] :Signals, PH DIST Z2 OP
, [Digital Channel 47] :Trigger, TRIGGER ONLY
, [Digital Channel 48] :Signals, PH DIST Z3 PKP
, [Digital Channel 48] :Trigger, TRIGGER ONLY
, [Digital Channel 49] :Signals, PH DIST Z3 OP
, [Digital Channel 49] :Trigger, TRIGGER ONLY
, [Digital Channel 50] :Signals, PH DIST Z4 PKP
, [Digital Channel 50] :Trigger, TRIGGER ONLY
, [Digital Channel 51] :Signals, PH DIST Z4 OP
, [Digital Channel 51] :Trigger, TRIGGER ONLY
, [Digital Channel 52] :Signals, PH DIST Z5 PKP
, [Digital Channel 52] :Trigger, TRIGGER ONLY
, [Digital Channel 53] :Signals, PH DIST Z5 OP
, [Digital Channel 53] :Trigger, TRIGGER ONLY
, [Digital Channel 54] :Signals, PHASE IOC1 OP
, [Digital Channel 54] :Trigger, TRIGGER ONLY
, [Digital Channel 55] :Signals, PHASE OV1 OP
, [Digital Channel 55] :Trigger, TRIGGER ONLY
, [Digital Channel 56] :Signals, PHASE SELECT AG
, [Digital Channel 56] :Trigger, OFF
, [Digital Channel 57] :Signals, PHASE SELECT BG
, [Digital Channel 57] :Trigger, OFF
, [Digital Channel 58] :Signals, PHASE SELECT CG
, [Digital Channel 58] :Trigger, OFF

, [Digital Channel 59] :Signals, PHASE SELECT AB
, [Digital Channel 59] :Trigger, OFF
, [Digital Channel 60] :Signals, PHASE SELECT BC
, [Digital Channel 60] :Trigger, OFF
, [Digital Channel 61] :Signals, PHASE SELECT CA
, [Digital Channel 61] :Trigger, OFF
, [Digital Channel 62] :Signals, PHASE SELECT ABG
, [Digital Channel 62] :Trigger, OFF
, [Digital Channel 63] :Signals, PHASE SELECT BCG
, [Digital Channel 63] :Trigger, OFF
, [Digital Channel 64] :Signals, PHASE SELECT CAG
, [Digital Channel 64] :Trigger, OFF
, [Digital Channel 65] :Signals, PHASE SELECT 3P
, [Digital Channel 65] :Trigger, OFF
, [Digital Channel 66] :Signals, PHASE TOC1 OP
, [Digital Channel 66] :Trigger, OFF
, [Digital Channel 67] :Signals, PHASE UV1 OP
, [Digital Channel 67] :Trigger, OFF
, [Digital Channel 68] :Signals, POTT OP
, [Digital Channel 68] :Trigger, TRIGGER ONLY
, [Digital Channel 69] :Signals, POWER SWING BLOCK
, [Digital Channel 69] :Trigger, TRIGGER ONLY
, [Digital Channel 70] :Signals, PUTT OP
, [Digital Channel 70] :Trigger, TRIGGER ONLY
, [Digital Channel 71] :Signals, SETTING GROUP ACT 1
, [Digital Channel 71] :Trigger, OFF
, [Digital Channel 72] :Signals, SETTING GROUP ACT 2
, [Digital Channel 72] :Trigger, OFF
, [Digital Channel 73] :Signals, SRC1 50DD OP
, [Digital Channel 73] :Trigger, TRIGGER ONLY
, [Digital Channel 74] :Signals, SRC1 VT FF OP
, [Digital Channel 74] :Trigger, TRIGGER ONLY
, [Digital Channel 75] :Signals, SYNC 1 DEAD S OP
, [Digital Channel 75] :Trigger, OFF
, [Digital Channel 76] :Signals, SYNC 1 SYNC OP
, [Digital Channel 76] :Trigger, OFF
, [Digital Channel 77] :Signals, SYNC 2 DEAD S OP
, [Digital Channel 77] :Trigger, OFF
, [Digital Channel 78] :Signals, SYNC 2 SYNC OP
, [Digital Channel 78] :Trigger, OFF
, [Digital Channel 79] :Signals, TRIP PHASE A

, [Digital Channel 79] :Trigger, TRIGGER/RETRIGGER
, [Digital Channel 80] :Signals, TRIP PHASE B
, [Digital Channel 80] :Trigger, TRIGGER/RETRIGGER
, [Digital Channel 81] :Signals, TRIP PHASE C
, [Digital Channel 81] :Trigger, TRIGGER/RETRIGGER
, [Digital Channel 82] :Signals, BKR1 A CLOSED
, [Digital Channel 82] :Trigger, OFF
, [Digital Channel 83] :Signals, BKR1 B CLOSED
, [Digital Channel 83] :Trigger, OFF
, [Digital Channel 84] :Signals, BKR1 C CLOSED
, [Digital Channel 84] :Trigger, OFF
, [Digital Channel 85] :Signals, BKR2 A CLOSED
, [Digital Channel 85] :Trigger, OFF
, [Digital Channel 86] :Signals, BKR2 B CLOSED
, [Digital Channel 86] :Trigger, OFF
, [Digital Channel 87] :Signals, BKR2 C CLOSED
, [Digital Channel 87] :Trigger, OFF
, [Digital Channel 88] :Signals, BKR1 CLOSED
, [Digital Channel 88] :Trigger, OFF
, [Digital Channel 89] :Signals, BKR2 CLOSED
, [Digital Channel 89] :Trigger, OFF
, [Digital Channel 90] :Signals, DCUB TX1
, [Digital Channel 90] :Trigger, OFF
, [Digital Channel 91] :Signals, HYBRID POTT TX1
, [Digital Channel 91] :Trigger, OFF
, [Digital Channel 92] :Signals, POTT TX1
, [Digital Channel 92] :Trigger, OFF
, [Digital Channel 93] :Signals, PUTT TX1
, [Digital Channel 93] :Trigger, OFF
, [Digital Channel 94] :Signals, PHASE TOC2 PKP B
, [Digital Channel 94] :Trigger, OFF
, [Digital Channel 95] :Signals, POWER SWING TRIP
, [Digital Channel 95] :Trigger, TRIGGER ONLY
, [Digital Channel 96] :Signals, DIR BLOCK OP
, [Digital Channel 96] :Trigger, TRIGGER ONLY
, [Digital Channel 97] :Trigger, OFF
LOCAL HMI: ANNUNCIATOR
, Page Layout, 4 x 6
, Alarm 1 Input :, PH DIST Z1 OP
, Alarm 1 Name :, Phase(Line1), Distance(Line2), Zone 1(Line3)

, Alarm 1 Color :, Red
, Alarm 2 Input :, PH DIST Z2 OP
, Alarm 2 Name :, Phase(Line1), Distance(Line2), Zone 2(Line3)
, Alarm 2 Color :, Red
, Alarm 3 Input :, PH DIST Z3 OP
, Alarm 3 Name :, Ground(Line1), Distance(Line2), Zone 3(Line3)
, Alarm 3 Color :, Red
, Alarm 4 Input :, PH DIST Z4 OP
, Alarm 4 Name :, Ground(Line1), Distance(Line2), Zone 4(Line3)
, Alarm 4 Color :, Red
, Alarm 5 Input :, LINE PICKUP OP
, Alarm 5 Name :, Line(Line1), Pickup(Line2), Operate(Line3)
, Alarm 5 Color :, Red
, Alarm 6 Input :, SRC1 VT FF OP
, Alarm 6 Name :, VT(Line1), Fuse(Line2), Failure(Line3)
, Alarm 6 Color :, Red
, Alarm 7 Input :, GND DIST Z1 OP
, Alarm 7 Name :, Ground(Line1), Distance(Line2), Zone 1(Line3)
, Alarm 7 Color :, Red
, Alarm 8 Input :, GND DIST Z2 OP
, Alarm 8 Name :, Ground(Line1), Distance(Line2), Zone 2(Line3)
, Alarm 8 Color :, Red
, Alarm 9 Input :, GND DIST Z3 OP
, Alarm 9 Name :, Ground(Line1), Distance(Line2), Zone 3(Line3)
, Alarm 9 Color :, Red
, Alarm 10 Input :, GND DIST Z4 OP
, Alarm 10 Name :, Ground(Line1), Distance(Line2), Zone 4(Line3)
, Alarm 10 Color :, Red
, Alarm 11 Input :, GROUND TOC1 OP
, Alarm 11 Name :, Ground(Line1), TOC1(Line2), Operate(Line3)
, Alarm 11 Color :, Red
, Alarm 12 Input :, GROUND IOC1 OP
, Alarm 12 Name :, Ground(Line1), IOC1(Line2), Operate(Line3)
, Alarm 12 Color :, Red
, Alarm 13 Input :, NTRL DIR OC1 FWD
, Alarm 13 Name :, NTRL(Line1), DIR OC(Line2), Forward(Line3)
, Alarm 13 Color :, Red
, Alarm 14 Input :, NTRL DIR OC1 REV
, Alarm 14 Name :, NTRL(Line1), DIR OC(Line2), Reverse(Line3)
, Alarm 14 Color :, Red
, Alarm 15 Input :, BKR FAIL 1 TRIP OP

, Alarm 15 Name :, Breaker 1(Line1), Fail(Line2), Operate(Line3)
, Alarm 15 Color :, Red
, Alarm 16 Input :, BKR FAIL 2 TRIP OP
, Alarm 16 Name :, Breaker 2(Line1), Fail(Line2), Operate(Line3)
, Alarm 16 Color :, Red
, Alarm 17 Input :, POWER SWING BLOCK
, Alarm 17 Name :, Power(Line1), Swing(Line2), Block(Line3)
, Alarm 17 Color :, Red
, Alarm 18 Input :, POWER SWING TRIP
, Alarm 18 Name :, Power(Line1), Swing(Line2), Trip(Line3)
, Alarm 18 Color :, Red
, Alarm 19 Input :, Remo Ip 1 On (RI1)
, Alarm 19 Name :, REM IP-1(Line1), Q(Line2), Recvd(Line3)
, Alarm 19 Color :, Red
, Alarm 20 Input :, Remo Ip 2 On (RI2)
, Alarm 20 Name :, REM IP-2(Line1), Data(Line2), Recvd(Line3)
, Alarm 20 Color :, Red
, Alarm 21 Input :, Remo Ip 3 On (RI3)
, Alarm 21 Name :, REM IP-3(Line1), Spare(Line2), (Line3)
, Alarm 21 Color :, Red
, Alarm 22 Input :, POTT OP
, Alarm 22 Name :, POTT(Line1), Scheme(Line2), Operate(Line3)
, Alarm 22 Color :, Red
, Alarm 23 Input :, DIR BLOCK OP
, Alarm 23 Name :, DCB(Line1), Scheme(Line2), Operate(Line3)
, Alarm 23 Color :, Red
, Alarm 24 Input :, D90-2 Off (RD1)
, Alarm 24 Name :, Remote (Line1), D90-2(Line2), OffLine(Line3)
, Alarm 24 Color :, Red
, Alarm 25 Input :, AR ENABLED
, Alarm 25 Name :, AR Enabled(Line1), (Line2), (Line3)
, Alarm 25 Color :, Blue
, Alarm 26 Input :, AR BKR 1 BLK
, Alarm 26 Name :, AR BKR 1 (Line1), BLK(Line2), (Line3)
, Alarm 26 Color :, Blue
, Alarm 27 Input :, AR LO
, Alarm 27 Name :, AR LO(Line1), (Line2), (Line3)
, Alarm 27 Color :, Blue
USER PROGRAMMABLE PUSHBUTTONS
, PB 2: Function, Self-reset

, PB 2: ID Text, Reset LO
, PB 2: On Text,
, PB 2: Off Text,
, PB 2: Set, Off
, PB 2: Reset, Off
, PB 2: Autoreset, Disabled
, PB 2: Autoreset Delay, 1.0 s
, PB 2: Remote Lock, Off
, PB 2: Local Lock, Off
, PB 2: Dropout Time, 0.0 s
, PB 2: Events, Enabled
, PB 20: Function, Self-reset
, PB 20: ID Text, Test
, PB 20: On Text, SDC
, PB 20: Off Text,
, PB 20: Set, Off
, PB 20: Reset, Off
, PB 20: Autoreset, Disabled
, PB 20: Autoreset Delay, 1.0 s
, PB 20: Remote Lock, Off
, PB 20: Local Lock, Off
, PB 20: Dropout Time, 0.0 s
, PB 20: Events, Enabled
DISPLAY PROPERTIES
, Default Front Panel Timeout, 60 min

APPENDIX – 2

FAULT CALCULATION USING MATLAB CODE FOR RELAY 1 AT STATION G

```
clc;
clear;

a=[1 1 1; 1 -0.5-i*0.866 -0.5+i*0.866; 1 -0.5+i*0.866 -0.5-i*0.866];
% A matrix
mva_base=100; % Base mva
ctr=1500/5;
ptr=1400/1;

% Values changing j
vs1=1*(cos(0*pi/180)+(i*sin(0*pi/180)));
vs2=1*(cos(5*pi/180)+(i*sin(5*pi/180)));
L1=6.734+(i*20.249); %Line impedance
L0=3*L1;
S1=i*10; %Source impedance
S2=S1;

format short

%%%%%%%%%%%%%%%%%%%%%%%%%%%%%%%%%%%%%%%%%%%%%%%%%%%%%%%%%%%%%%%%%%%%%%%%%%
% PER UNIT VALUE CALCULATIONS
%%%%%%%%%%%%%%%%%%%%%%%%%%%%%%%%%%%%%%%%%%%%%%%%%%%%%%%%%%%%%%%%%%%%%%%%%%

ibase=mva_base/(1.732*161);
zbase=(161*161)/mva_base;
rs11=S1/zbase
rs21=rs11
line1=L1/zbase
line0=L0/zbase
in1=(vs1-vs2)/(rs11+line1+rs21);
ip1=(vs2-vs1)/(rs11+line1+rs21);

j=105/100; %Percent of line where fault occurs

x11=line1*j;
x1_lhs=rs11+x11;
x1_rhs=(line1*(1-j))+rs21;
x_thevenin=(x1_lhs*x1_rhs)/(x1_lhs+x1_rhs);
z1=x_thevenin;
x2_lhs=x1_lhs;
x2_rhs=x1_rhs;
z2=z1;
x0_lhs=(line0*j)+(3*rs11);
x0_rhs=((1-j)*line0)+(3*rs21);
z0=(x0_lhs*x0_rhs)/(x0_lhs+x0_rhs);
z=[z0 0 0; 0 z1 0 ; 0 0 z2];
line2=line1;
ibase_ct=1000*mva_base/(1.732*161*ctr);
vbase_pt=1000*161/(ptr*1.732);
```

```

%%%%%%%%%%%%%%%%%%%%%%%%%%%%%%%%%%%%%%%%%%%%%%%%%%%%%%%%%%%%%%%%%%%%%%%%
%           PREFault CURRENTS AND VOLTAGES CALCULATION
%%%%%%%%%%%%%%%%%%%%%%%%%%%%%%%%%%%%%%%%%%%%%%%%%%%%%%%%%%%%%%%%%%%%%%%%

```

```

vpre=vs1-vs2;
impedance=(rs11+line1+rs21);
seq1=vpre/impedance;
iseq=[0; seq1; 0];
IPHASE1=a*iseq;
IPHASE=IPHASE1*ibase_ct;
v_s1=vs1-(seq1*rs11);
v_s1_seq=[0;v_s1;0];
VPHASE1=a*v_s1_seq;
VPHASE=VPHASE1*vbase_pt;
v_s2=vs2-(seq1*rs21);
v_s2_seq=[0; v_s2; 0];
VPHASE21=a*v_s2_seq;
VPHASE2=VPHASE21*vbase_pt;

MAG_VS1_PRE=abs (VPHASE)
ANGLE_VS1_PRE=angle (VPHASE) *180/pi

MAG_VS2_PRE=abs (VPHASE2)
ANGLE_VS2=angle (VPHASE2) *180/pi

MAG_IPRE=abs (IPHASE)
ANGLE_IPRE=angle (IPHASE) *180/pi;

```

% in ampere

```

%%%%%%%%%%%%%%%%%%%%%%%%%%%%%%%%%%%%%%%%%%%%%%%%%%%%%%%%%%%%%%%%%%%%%%%%
%           SEQUENCE CURRENTS AND VOLTAGES CALCULATION
%%%%%%%%%%%%%%%%%%%%%%%%%%%%%%%%%%%%%%%%%%%%%%%%%%%%%%%%%%%%%%%%%%%%%%%%

```

```

% 1=three phase fault
% 2=single phase to ground fault
% 3=line to line fault
% 4=line to line to ground fault

```

```

vss1=[0;vs1;0];
fault='1';

switch (fault)
case {'1'}
    display('three phase fault')
    If=vs1/x_thevenin;
    i_sequence=[0; If; 0];
    i_phase=a*i_sequence;
    %fault current in different phases in per unit
    %ifault=ibase*If % kiloampere
    v_sequence=vss1-(z*i_sequence);
    v_phase=a*v_sequence;
case {'2'}
    display('single phase fault')
    i0=vs1/(z0+z1+z2);
    i_sequence=[i0; i0 ; i0];

```

```

        i_phase=a*i_sequence;
        v_sequence=vss1-(z*i_sequence);
        v_phase=a*v_sequence;

    case {'3'}
        display('line to line fault')
        i1=vs1/(z1+z2);
        i2=-i1;
        i0=0;
        i_sequence=[i0;i1;i2];
        i_phase=a*i_sequence;
        v_sequence=vss1-(z*i_sequence);
        v_phase=a*v_sequence;
    case {'4'}
        display('line to line fault to ground')
        i1=vs1/(z1+((z2*z0)/(z2+z0)));
        i2=-i1*(z0/(z0+z2));
        i0=-i1*(z2/(z0+z2));
        i_sequence=[i0;i1;i2];
        i_phase=a*i_sequence;
        v_sequence=vss1-(z*i_sequence);
        v_phase=a*v_sequence;
end

%%%%%%%%%%%%%%%%%%%%%%%%%%%%%%%%%%%%%%%%%%%%%%%%%%%%%%%%%%%%%%%%%%%%%%%%
%                               FAULT VALUES AT THE INSTRUMENT TRANSFORMER
%%%%%%%%%%%%%%%%%%%%%%%%%%%%%%%%%%%%%%%%%%%%%%%%%%%%%%%%%%%%%%%%%%%%%%%%

x_lhs=[x0_lhs x1_lhs x2_lhs];
x_rhs=[x0_rhs x1_rhs x2_rhs];
x_seq_line=[line0; line1; line2];
for kk=1:3
    i_primary_inst_trans(kk,1)=(i_sequence(kk,1)*x_rhs(1,kk))/(...
        x_lhs(1,kk)+x_rhs(1,kk));
    v_primary_inst_trans(kk,1)=(v_sequence(kk,1)+(...
        i_primary_inst_trans(kk,1)*(x_seq_line(kk,1)*j)));
end
i_phase_inst_trans=a*i_primary_inst_trans;
v_phase_inst_trans=a*v_primary_inst_trans;
ibase_ct=1000*mva_base/(1.732*161*ctr);
vbase_pt=1000*161/(1.732*ptr);

%%%%%%%%%%%%%%%%%%%%%%%%%%%%%%%%%%%%%%%%%%%%%%%%%%%%%%%%%%%%%%%%%%%%%%%%
%                               FAULT VALUES AT THE RELAY
%%%%%%%%%%%%%%%%%%%%%%%%%%%%%%%%%%%%%%%%%%%%%%%%%%%%%%%%%%%%%%%%%%%%%%%%

i_phase_relay=i_phase_inst_trans*ibase_ct;
v_phase_relay=v_phase_inst_trans*vbase_pt;
irelay_mag=abs(i_phase_relay)
irelay_angle=angle(i_phase_relay)*180/pi
vrelay_mag=abs(v_phase_relay)
vrelay_angle=angle(v_phase_relay)*180/pi

```

APPENDIX – 3

FAULT CALCULATION USING MATLAB CODE FOR RELAY 2 AT STATION H

```
clc;
clear;

a=[1 1 1; 1 -0.5-i*0.866 -0.5+i*0.866; 1 -0.5+i*0.866 -0.5-i*0.866];
ctr=1500/5;
ptr=1400/1;
%values changing j
vs1=1*(cos(0*pi/180)+(i*sin(0*pi/180)));
vs2=1*(cos(5*pi/180)+(i*sin(5*pi/180)));
L1=6.734+(i*20.249);
L0=3*L1;
S1=i*10;
S2=S1;
format short

%%%%%%%%%%%%%%%%%%%%%%%%%%%%%%%%%%%%%%%%%%%%%%%%%%%%%%%%%%%%%%%%%%%%%%%%%%
%                               PER UNIT VALUE CALCULATIONS
%%%%%%%%%%%%%%%%%%%%%%%%%%%%%%%%%%%%%%%%%%%%%%%%%%%%%%%%%%%%%%%%%%%%%%%%%%

mva_base=100
ibase=mva_base/(1.732*161);
zbase=(161*161)/mva_base;
rs11=S1/zbase;
rs21=rs11
line1=L1/zbase;
line0=L0/zbase;
in1=(vs1-vs2)/(rs11+line1+rs21);
ip1=(vs2-vs1)/(rs11+line1+rs21);

j=10/100           %percent of line where fault occurs same as first relay

%%%%%%%%%%%%%%%%%%%%%%%%%%%%%%%%%%%%%%%%%%%%%%%%%%%%%%%%%%%%%%%%%%%%%%%%%%
%                               PER UNIT VALUE CALCULATIONS
%%%%%%%%%%%%%%%%%%%%%%%%%%%%%%%%%%%%%%%%%%%%%%%%%%%%%%%%%%%%%%%%%%%%%%%%%%
x11=line1*j;
x1_lhs=rs11+x11;
x1_rhs=(line1*(1-j))+rs21;
x_thevenin=(x1_lhs*x1_rhs)/(x1_lhs+x1_rhs);
z1=x_thevenin;
x2_lhs=x1_lhs;
x2_rhs=x1_rhs;
z2=z1;
x0_lhs=(3*rs11)+(line0*j);
x0_rhs=((1-j)*line0)+(3*rs21);
z0=(x0_lhs*x0_rhs)/(x0_lhs+x0_rhs);
z=[z0 0 0;0 z1 0 ; 0 0 z2];
line2=line1;
```

```

%%%%%%%%%%%%%%%%%%%%%%%%%%%%%%%%%%%%%%%%%%%%%%%%%%%%%%%%%%%%%%%%%%%%%%%%
%                               SEQUENCE CURRENTS AND VOLTAGES CALCULATION
%%%%%%%%%%%%%%%%%%%%%%%%%%%%%%%%%%%%%%%%%%%%%%%%%%%%%%%%%%%%%%%%%%%%%%%%

                                % 1=three phase fault
                                % 2=single phase to ground fault
                                % 3=line to line fault
                                % 4=line to line to ground fault

vss1=[0;vs2;0];                %vs1 changed to vs2 for right side
relay
fault='1';

switch (fault)
case {'1'}
    display('three phase fault')
    If=vs2/x_thevenin;
    i_sequence=[0; If; 0]
    i_phase=a*i_sequence
                                %fault current in different phases in per unit
                                %ifault=ibase*If % kiloamper
    v_sequence=vss1-(z*i_sequence)
    v_phase=a*v_sequence
case {'2'}
    display('single phase fault')
    i0=vs2/(z0+z1+z2);
    i_sequence=[i0; i0 ; i0]
    i_phase=a*i_sequence
    v_sequence=vss1-(z*i_sequence)
    v_phase=a*v_sequence

case {'3'}
    display('line to line fault')
    i1=vs2/(z1+z2);
    i2=-i1;
    i0=0;
    i_sequence=[i0;i1;i2]
    i_phase=a*i_sequence
    v_sequence=vss1-(z*i_sequence)
    v_phase=a*v_sequence
case {'4'}
    i1=vs2/(z1+((z2*z0)/(z2+z0)));
    i2=-i1*(z0/(z0+z2));
    i0=-i1*(z2/(z0+z2));
    i_sequence=[i0;i1;i2];
    i_phase=a*i_sequence;
    v_sequence=vss1-(z*i_sequence);
    v_phase=a*v_sequence;
end
I=i_phase*ibase*1000;
v=round(v_phase);

```

```

%%%%%%%%%%%%%%%%%%%%%%%%%%%%%%%%%%%%%%%%%%%%%%%%%%%%%%%%%%%%%%%%%%%%%%%%
%                               FAULT VALUES AT THE INSTRUMENT TRANSFORMER
%%%%%%%%%%%%%%%%%%%%%%%%%%%%%%%%%%%%%%%%%%%%%%%%%%%%%%%%%%%%%%%%%%%%%%%%

```

```

x_lhs=[x0_lhs x1_lhs x2_lhs];
x_rhs=[x0_rhs x1_rhs x2_rhs];
x_seq_line=[line0; line1; line2];
for kk=1:3
    i_primary_inst_trans(kk,1)=(i_sequence(kk,1)*x_lhs(1, kk))/(...
        x_lhs(1, kk)+x_rhs(1, kk));
    v_primary_inst_trans(kk,1)=(v_sequence(kk,1)+(...
        i_primary_inst_trans(kk,1)*(x_seq_line(kk,1)*(1-j))));
end
i_phase_inst_trans=a*i_primary_inst_trans;
v_phase_inst_trans=a*v_primary_inst_trans;
ibase_ct=1000*mva_base/(1.732*161*ctr);
vbase_pt=1000*161/(1.732*ptr);

```

```

%%%%%%%%%%%%%%%%%%%%%%%%%%%%%%%%%%%%%%%%%%%%%%%%%%%%%%%%%%%%%%%%%%%%%%%%
%                               FAULT VALUES AT THE RELAY
%%%%%%%%%%%%%%%%%%%%%%%%%%%%%%%%%%%%%%%%%%%%%%%%%%%%%%%%%%%%%%%%%%%%%%%%

```

```

i_phase_relay=i_phase_inst_trans*ibase_ct;
v_phase_relay=v_phase_inst_trans*vbase_pt;
irelay_mag=abs(i_phase_relay)
irelay_angle=angle(i_phase_relay)*180/pi
vrelay_mag=abs(v_phase_relay)
vrelay_angle=angle(v_phase_relay)*180/pi

```